

Service Manual

PIONEER®
The Art of Entertainment

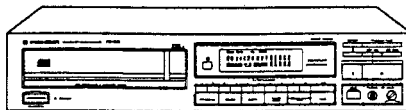

ORDER NO.
ARP2470

COMPACT DISC PLAYER

PD-201

PD-101

PD-201 AND PD-101 HAVE THE FOLLOWING:

Type	Model		Power Requirement	Remarks
	PD-201	PD-101		
KU	○	○	AC120V only	
KC	○	○	AC120V only	
KUXJS	○	○	AC120V only	
KCXJS	○	○	AC120V only	

- This manual is applicable to PD-201/KU, KC, KUXJS, KCXJS, PD-101/KU, KC, KUXJS and KCXJS types.
- For the following: PD-201/KC, KUXJS, KCXJS, PD-101/KU, KC, KUXJS and KCXJS types, refer to pages 43-44.

CONTENTS

1. SAFETY INFORMATION	2
2. DISASSEMBLY	3
3. EXPLODED VIEWS, PACKING AND PARTS LIST	5
4. PCB CONNECTION AND SCHEMATIC DIAGRAM	12
5. PCB PARTS LIST	26
6. ADJUSTMENTS	28
7. FOR PD-201/KC, KUXJS, KCXJS, PD-101/KU, KC, KUXJS AND KCXJS TYPES	43
8. PANEL FACILITIES	45
9. SPECIFICATIONS	45

PIONEER ELECTRONIC CORPORATION 4-1, Meguro 1-Chome, Meguro-ku, Tokyo 153, Japan
PIONEER ELECTRONICS SERVICE INC. P.O. Box 1760, Long Beach, California 90801 U.S.A.
PIONEER ELECTRONICS OF CANADA, INC. 300 Allstate Parkway Markham, Ontario L3R 0P2 Canada
PIONEER ELECTRONIC [EUROPE] N.V. Haven 1087 Keetberglaan 1, 9120 Melsele, Belgium
PIONEER ELECTRONICS AUSTRALIA PTY. LTD. 178-184 Boundary Road, Braeside, Victoria 3195, Australia TEL: [03] 580-9911
© PIONEER ELECTRONIC CORPORATION 1992

SJ MAR. 1992 Printed in Japan

This service manual is intended for qualified service technicians; it is not meant for the casual do-it-yourselfer. Qualified technicians have the necessary test equipment and tools, and have been trained to properly and safely repair complex products such as those covered by this manual. Improperly performed repairs can adversely affect the safety and reliability of the product and may void the warranty. If you are not qualified to perform the repair of this product properly and safely, you should not risk trying to do so and refer the repair to a qualified service technician.

WARNING

Lead in solder used in this product is listed by the California Health and Welfare agency as a known reproductive toxicant which may cause birth defects or other reproductive harm (California Health & Safety Code, Section 25249.5).

When servicing or handling circuit boards and other components which contain lead in solder, avoid unprotected skin contact with the solder. Also, when soldering do not inhale any smoke or fumes produced.

1. SAFETY INFORMATION

(FOR USA MODEL ONLY)

1. SAFETY PRECAUTIONS

The following check should be performed for the continued protection of the customer and service technician.

LEAKAGE CURRENT CHECK

Measure leakage current to a known earth ground (water pipe, conduit, etc.) by connecting a leakage current tester such as Simpson Model 229-2 or equivalent between the earth ground and all exposed metal parts of the appliance (input/output terminals, screwheads, metal overlays, control shaft, etc.). Plug the AC line cord of the appliance directly into a 120V AC 60Hz outlet and turn the AC power switch on. Any current measured must not exceed 0.5mA.

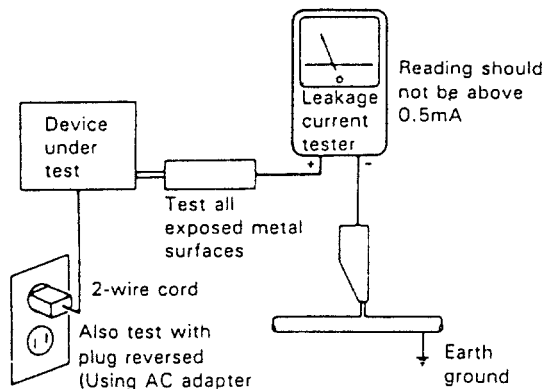

AC Leakage Test

ANY MEASUREMENTS NOT WITHIN THE LIMITS OUTLINED ABOVE ARE INDICATIVE OF A POTENTIAL SHOCK HAZARD AND MUST BE CORRECTED BEFORE RETURNING THE APPLIANCE TO THE CUSTOMER.

2. PRODUCT SAFETY NOTICE

Many electrical and mechanical parts in the appliance have special safety related characteristics. These are often not evident from visual inspection nor the protection afforded by them necessarily can be obtained by using replacement components rated for voltage, wattage, etc. Replacement parts which have these special safety characteristics are identified in this Service Manual.

Electrical components having such features are identified by marking with a Δ on the schematics and on the parts list in this Service Manual.

The use of a substitute replacement component which does not have the same safety characteristics as the PIONEER recommended replacement one, shown in the parts list in this Service Manual, may create shock, fire, or other hazards.

Product Safety is continuously under review and new instructions are issued from time to time. For the latest information, always consult the current PIONEER Service Manual. A subscription to, or additional copies of, PIONEER Service Manual may be obtained at a nominal charge from PIONEER.

2. DISASSEMBLY

2.1 REMOVING THE TRAY (See Fig. 2 - 1.)

As the claw of the tray cannot be bent, remove the tray according to the following procedures.

- ① Remove the bonnet.
- ② Press the OPEN/CLOSE (▲) button on the front panel, and move the tray to the OPEN position.
- ③ Remove the tray name plate.
- ④ Push in the tray.
- ⑤ Remove the clamber base.
- ⑥ Remove the operation panel.
- ⑦ Pull out the tray.

Note: When opening with your hands, do so as follows.

- 1) Pull the right edge (A) of the clamber cam in the direction of the operation panel. The servo mechanism descends, the clamber is released, and the tray opens about 2 cm.

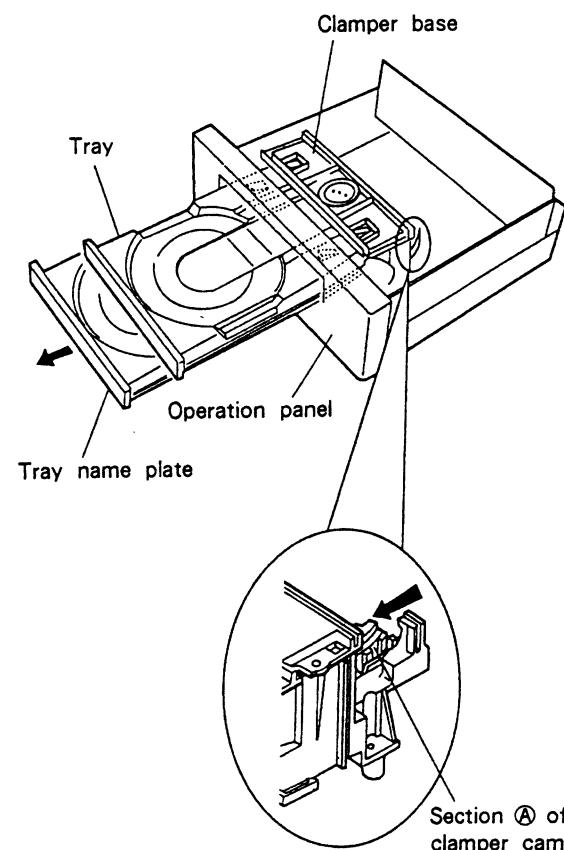

Fig. 2 - 1.

2.2 REMOVING THE SERVO MECHANISM ASSEMBLY

- ① Remove the tray and clamber base. (See 2.1.)
- ② With the servo mechanism assembly in the descended condition (tray open position), remove the 4 screws (B) holding this assembly, and screw (C) holding the ground lead. Cut the binder holding the bundle of wires onto the loading base with a pair of nippers.

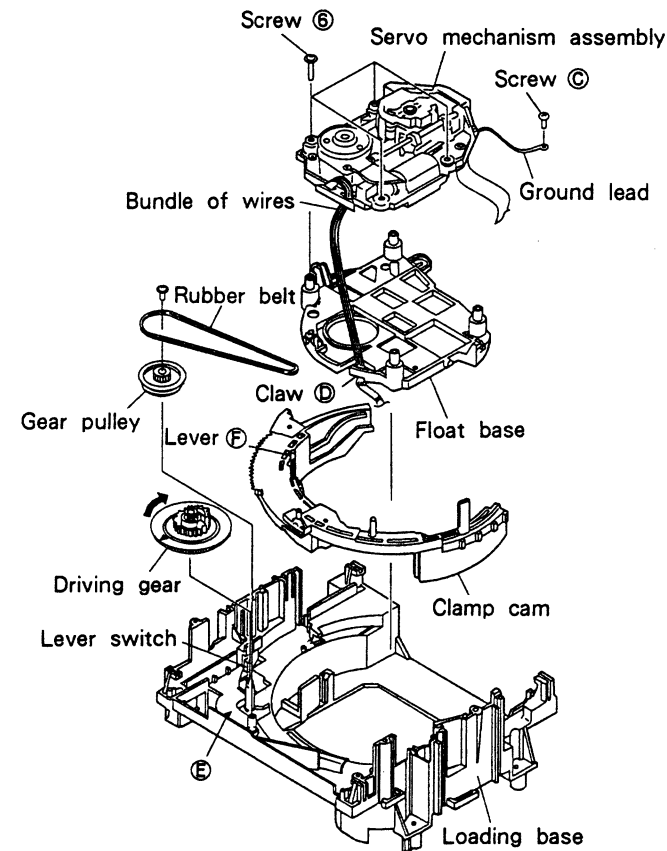

Fig. 2 - 2.

2.3 REMOVING THE FLOAT BASE (See Fig. 2 - 2.)

- ① Remove the servo mechanism assembly. (See 2.2.)
- ② Rotate the driving gear in the clockwise direction fully. The clamp cam will rotate in the counterclockwise direction, and the float base will rise.
- ③ After removing the bundle of wires from claw (D) of the float base, remove the float base.

Note: If the clamp cam does not rotate even if the driving gear is rotated, it means that these gears are not engaged. In this case, engage them in the correct position according to the following procedures, and rotate the driving gear.

- 1) Adjust the ▼ mark of the driving gear (on the round hole) to the ▲ mark (E) of the loading base.
- 2) Rotate lever (F) on the clamp cam in the counterclockwise direction.

2.4 REMOVING THE CLAMP CAM

- ① Remove the float base. (See 2.3.)
- ② Remove the gear pulley and driving gear.
- ③ After rotating the clamp cam fully in the counter clockwise direction, pull it up.

2.5 REMOVING THE MOTHER BOARD ASSEMBLY

- ① Remove the tray. (See 2.1.)
- ② Remove the operation panel and rear base. When removing the operation panel, remove the flat cable for the transformer board and the mother board assembly. Moreover, when removing the rear base, remove the cap of the optical digital output terminal.
- ③ Remove screw (C) holding the mother board assembly.
- ④ Remove the bundle of wires of the mother board assembly from claw (H) of the loading base.
- ⑤ After removing the board from the PCB holder in the order of ① and ② shown in Fig. 2 - 3, pull it out.

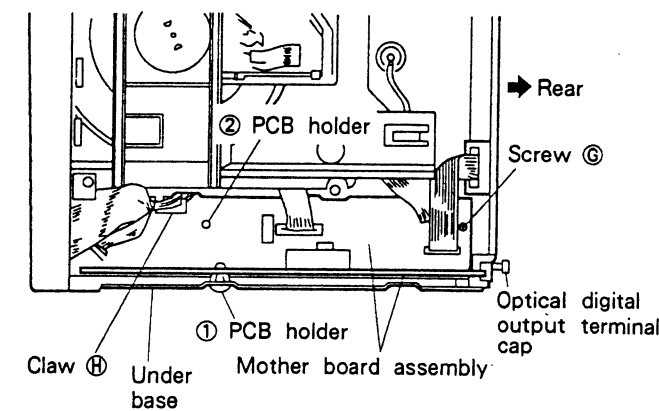

Fig. 2 - 3.

Note 1: After removing the board from the PCB holder (1), move the board slightly to prevent it from attaching to the PCB holder once again. Or, remove the PCB holder (1) from the under base (chassis).

Note 2: The mother board assembly is a L-shaped board in which two boards are connected by a jumper wire. (See Fig. 2 - 4.)

During removing and installing, be careful not to bend the jumper wire, apply excessive force onto any part as these may break the jumper wire, cause pattern floating, etc.

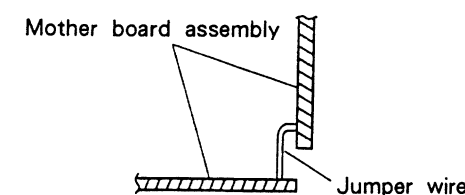

Fig. 2 - 4. Side view of mother board assembly

- ⑥ When examining the board, etc., move the mother board assembly towards the under base as shown in Fig. 2 - 5., and insert the notch of this board to the hook of the rear base to hold it in place. Moreover, connect the flat cable as before.

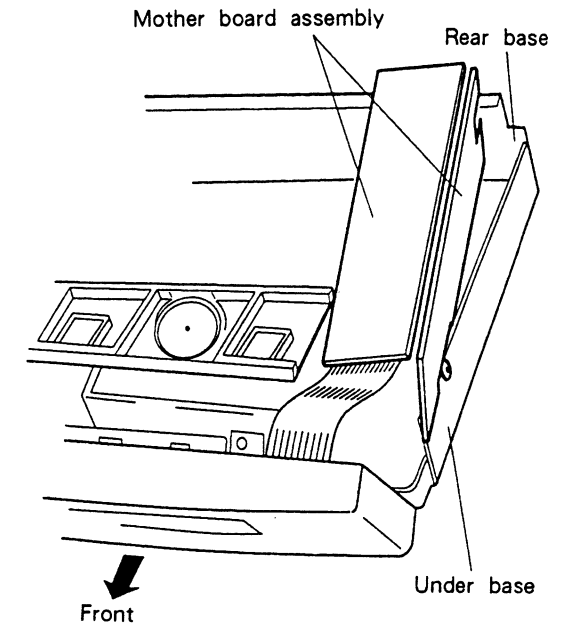

Fig. 2 - 5.

2.6 INSTALLING THE CLAMP CAM

- ① While pushing down the lever switch on the loading base towards the transformer board assembly, install the clamp cam.

2.7 INSTALLING THE FLOAT BASE

- ① Rotate the clamp cam in the counterclockwise direction fully, and install the float base. For details on rotating the clamp cam, refer to "2.3 Removing the Float Base".

2.8 INSTALLING THE TRAY

- ① Rotate the driving gear in the counterclockwise direction, and lower the servo mechanism assembly to the maximum.
- ② Rotate the driving gear in the counterclockwise direction, and adjust the ▼ mark of the driving gear (on the round hole) to the ▲ mark of the loading base.
- ③ Insert the tray.

Note 1: If the servo mechanism assembly does not descend even if the driving gear is rotated, it means that the gears are not engaged.

In this case, perform ②, and rotate the driving gear once again.

Note 2: The servo mechanism assembly will not rise fully even if the tray is inserted completely. However, it rises to the maximum automatically when the power is supplied.

3. EXPLODED VIEWS, PACKING AND PARTS LIST

3.1 EXTERIOR

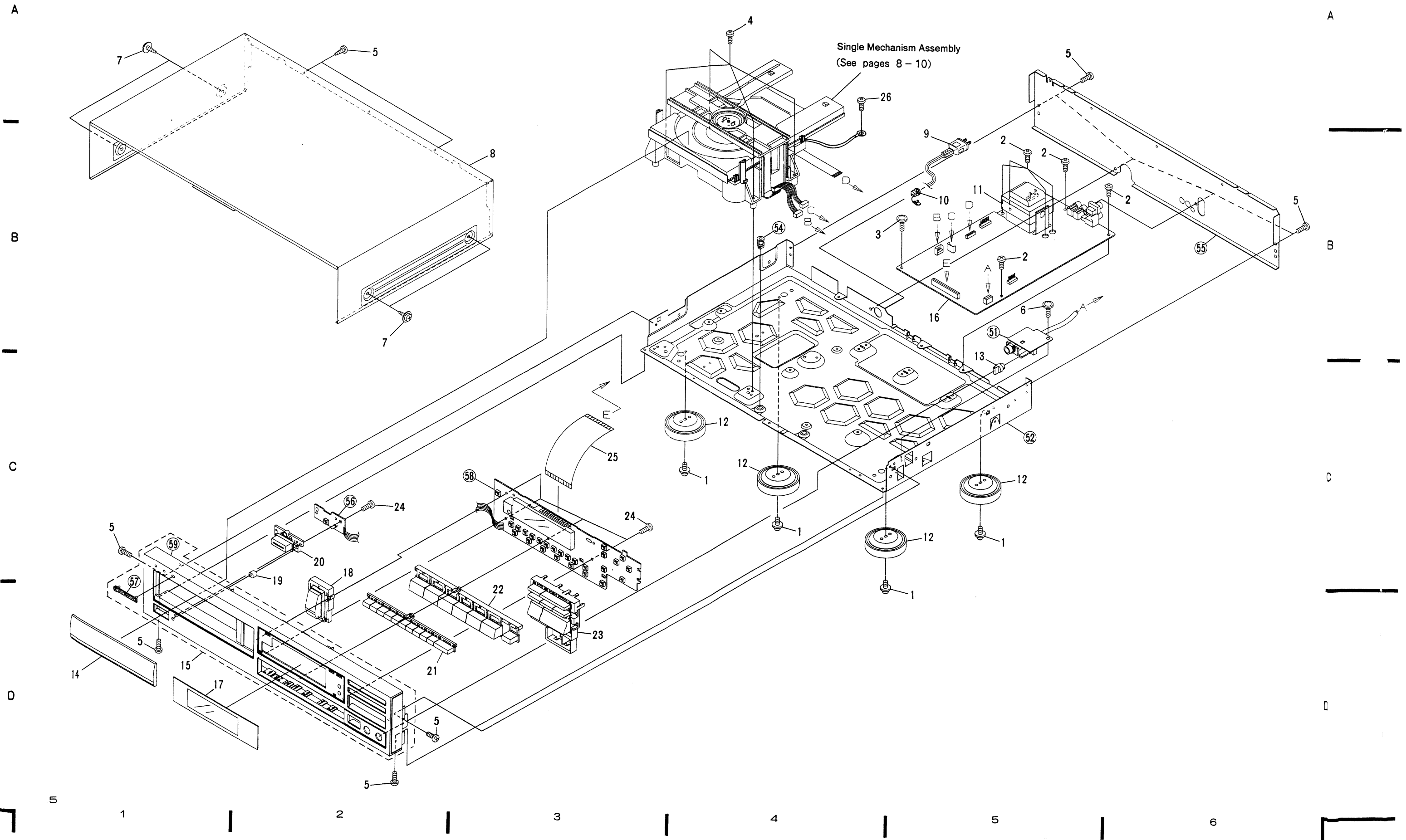

NOTES:

- The parts with an encircled number are generally unavailable because they are not in our Master Spare Parts List.
- The Δ mark found on some component parts indicates the importance of the safety factor of the part. Therefore, when replacing, be sure to use parts of identical designation.
- Parts marked by "⊙" are not always kept in stock. Their delivery time may be longer than usual or they may be unavailable.

Parts List

Mark	No.	Description	Part No.
	1	Screw	IBZ30P100FCC
	2	Screw	BBZ30P060FMC
	3	Screw	IBZ30P150FCC
	4	Screw	BBZ30P160FMC
	5	Screw	BBZ30P080FZK
	6	Screw	IBZ30P080FCC
	7	Screw	FBT40P080FZK
	8	Bonnet	PYY1147
Δ	9	AC power cord	PDG1040
Δ	10	Strain relief	CM - 22
Δ	11	Power transformer	PTT1235
	12	Insulator (ABS)	PNW1912
	13	Headphone knob	PAC1370
	14	Tray name plate (ABS)	PNW2134
	15	Function panel assembly	PEA1191
⊙	16	Mother board assembly	PWM1657
	17	Display window B	PAM1543
	18	O/C button (ABS)	PAC1688
	19	LED lens (ABS)	PNW2019
	20	Power button (ABS)	PAC1540
	21	10 key A (ABS)	PAC1635
	22	Program button	PAC1636
	23	Play button A	PAC1633
	24	Screw	PPZ30P120FMC
	25	32P F.F.C./30V	PDD1041
	26	Screw	PDZ30P050FMC
	51	Headphone PCB assembly	PWZ2298
	52	Under base	PNA1732
	53	
	54	PCB spacer	PNY - 404
	55	Rear base	PNA1726
	56	SW PCB assembly	PWZ2294
	57	PIONEER badge	PAM1407
	58	Function board assembly	PWZ2284
	59	Function Panel C	PNW2195

3.2 MECANISM SECTION

Parts List

Mark	No.	Description	Part No.
	1	Lever switch (CLAMP)	DSK1003
	2	Screw	PBA1048
	3	Rubber belt	PEB1193
	4	Motor pulley	PNW1634
	5	Tray	PNW2031
	6	Floating base	PNW2032
	7	Drive gear	PNW2033
	8	Gear pulley	PNW2034
	9	Clamper base	PNW2035
	10	Clamp cam	PNW2036
	11	DC motor (0.75W) (LOADING)	PXM1010
	12	Floating rubber	PEB1014
	13	Floating rubber	PEB1132
	14	Screw	BPZ26P080FMC
	15	Screw	Z39 - 018
	16	Screw	PMZ26P040FMC
	17	Push switch (INSIDE)	DSG1014
	18	Earth spring	PBH1084
	19	Drive spring	PBH1009
	20	Plate spring	PBK1057
	21	Belt	PEB1072
	22	Drive screw	PLA1003
	23	Guide bar	PLA1071
	24	Pulley	PNW1066
	25	Half nut	PNW1605
	26	Disc table	PNW1608
	27	Motor pulley	PNW1634
	28	DC motor (1.7W) (CARRIAGE)	PXM1013
	29	DC motor assembly (SPINDLE) (with oil)	PEA1028
	30	Pickup assembly	PEA1030
	31	Variable resistor (VR1) (3.3k Ω)	PCP1008
	32	Chip capacitor (1/16V)	CKSYF105Z16
	33	Screw	PMZ20P030FMC
	34	Screw	PBZ30P080FMC
	35	Screw	BPZ20P080FMC
	36	Screw	JFZ20P025FMC

Mark	No.	Description	Part No.
	101	Clamp magnet	PMF1014
	102	Yoke	PNB1216
	103	
	104	Clamper S	PNW1609
	105	Loading base	PNW2030
	106	
	107	Servo mechanism assembly	PXA1406
	108	2mm pitch connector assembly (5P)	PDE1169
	109	Motor base	PNB1211
	110	Mechanism base	PNB1230
	111	Earth lead unit	PDF1074
	112	Mechanism chassis	PNW1604

• How to install the disc table

- 1 Use nippers or other tool to cut the two sections marked (A) in figure 1. Then remove the spacer.
- 2 While supporting the spindle motor shaft with the stopper, put spacer on top of the motor base (angled so it doesn't touch section (B)), and stick the disc table on top (takes about 9kg pressure). Take off the spacer.

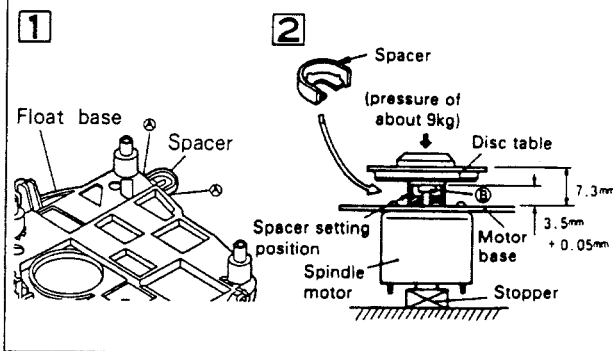

Mechanism Section

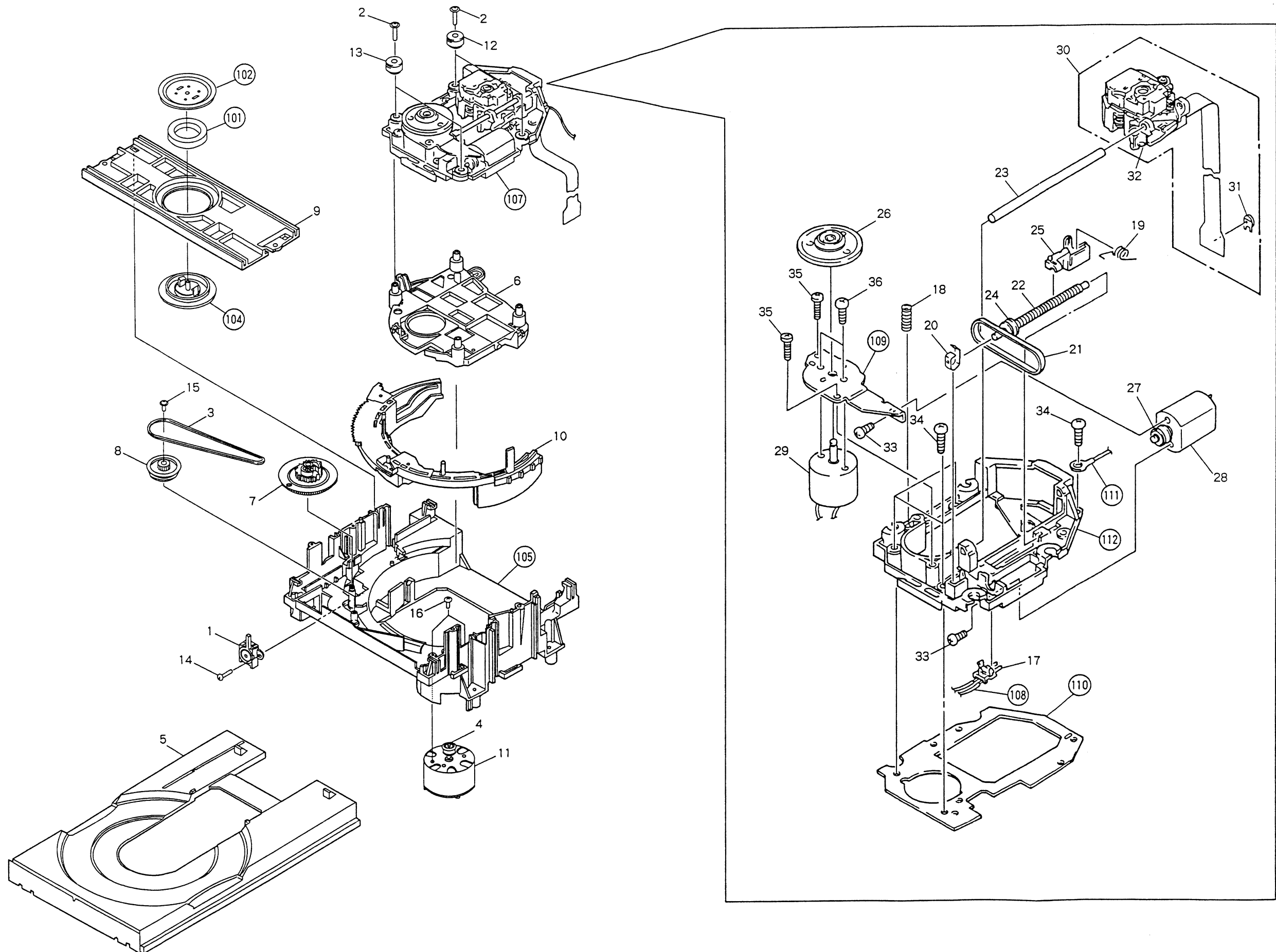

A
B
C
D

A
B
C
D

3.3 PACKING

Parts List

Mark	No.	Description	Part No.
	1	Connection cord with mini plug	PDE - 319
	2	Connection cord with pin plug	PDE1109
	3	Operating instructions (English)	PRB1159
	4	Remote control unit	PWW1061
	5	Protector F	PHA1116
	6	Protector R	PHA1117
	7	CD packing case	PHG1748
	8	Sheet	Z23 - 007
	9	Battery cover	PZN1010
51		Dry cell battery (UM - 4) VEM - 022	

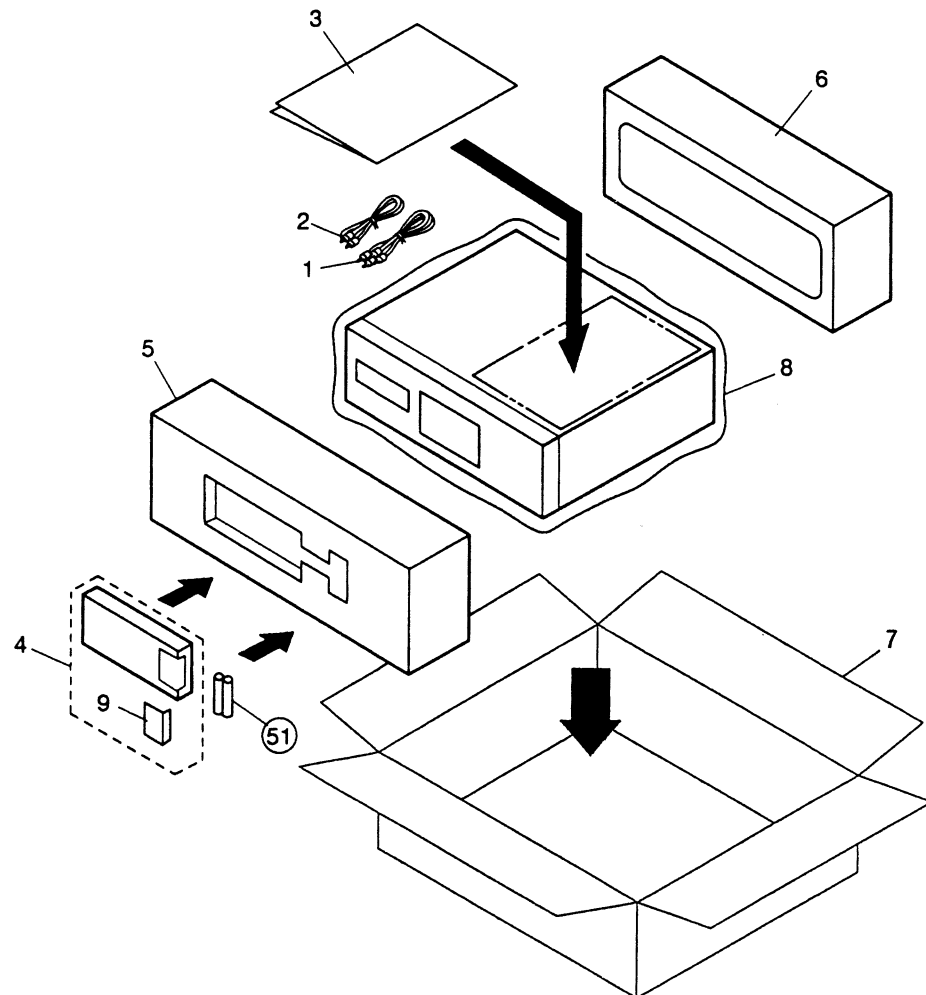

4. PCB CONNECTION AND SCHEMATIC DIAGRAM

1. RESISTORS :

Indicated in Ω , 1/4W, 1/6W, 1/8W, $\pm 5\%$ tolerance unless otherwise noted k; k Ω , M; M Ω , (F); $\pm 1\%$, (G); $\pm 2\%$, (K); $\pm 10\%$, (M); $\pm 20\%$ tolerance.

2. CAPACITORS :

Indicated in capacity (μ F) /voltage (V) unless otherwise noted p; pF. Indication without voltage is 50V except electrolytic capacitor.

3. VOLTAGE CURRENT :

; DC voltage (V) at play state.

; DC current at play state.

; Value in () is DC current at stop state.

4. OTHERS :

; Signal route.

; Adjusting point.

The Δ mark found on some component parts indicates the importance of the safety factor of the part. Therefore, when replacing, be sure to use parts of identical designation.

* marked capacitors and resistors have parts numbers.

This is the basic schematic diagram, but the actual circuit may vary due to improvements in design.

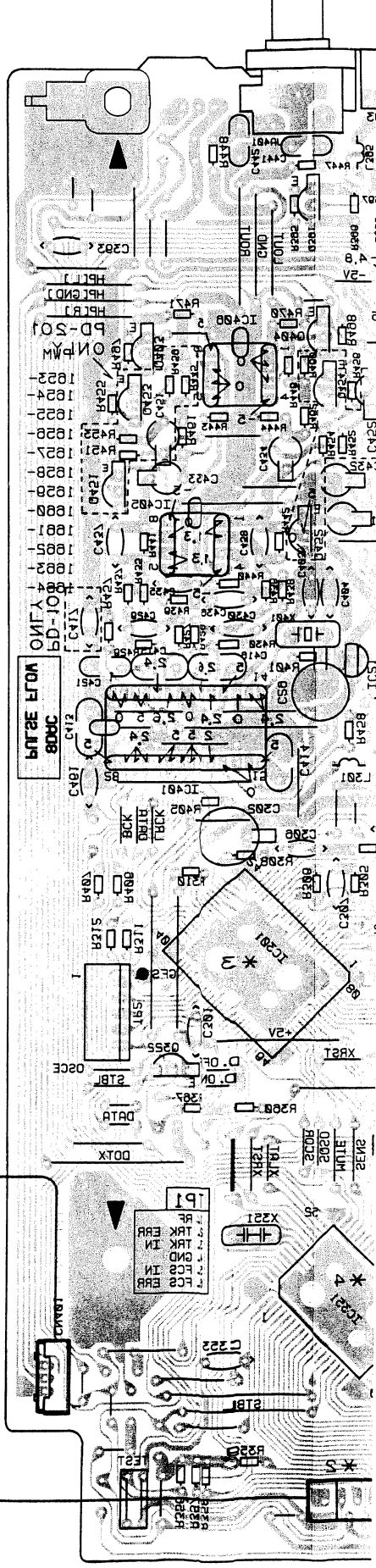

IC301	HFM30R-1	HFM35R-1
IC351	HFM30S-1	HFM35S-1
* 2	PD-101	PD-501
* 1	D3A1	USED
	PD-101	SHORT

* 3
IC301 (CXD5200AG)

Pin No.	Volts	Pin No.	Volts	Pin No.	Volts	Pin No.	Volts
1	2.0	21	0	41	NC	61	NC
2	NC	22	2.5	42	2.0	62	NC
3	2.0	23	2.0	43	NC	63	NC
4	2.6	24	2.5	44	NC	64	NC
5	NC	25	NC	45	NC	65	0
6	2.0	26	0	46	4.4	66	3.3 ~ 4.6
7	NC	27	2.5	47	0	67	2.0
8	NC	28	NC	48	0	68	0
9	0	29	0	49	0 ~ 0.3	69	5.1 ~ 3.0
10	0	30	NC	50	NC	70	2.0
11	NC	31	1.3 ~ 1.5	51	NC	71	2.0
12	0	32	2.5	52	0	72	2.0
13	NC	33	2.0	53	2.5	73	2.0
14	NC	34	2.5	54	NC	74	2.0
15	NC	35	NC	55	0	75	2.0
16	NC	36	NC	56	NC	76	0
17	0	37	NC	57	NC	77	2.0
18	2.5	38	NC	58	NC	78	2.0
19	2.4	39	NC	59	0	79	2.0
20	2.4	40	NC	60	NC	80	0

* 4
IC351 (PD4394A)

Pin No.	Volts	Pin No.	Volts	Pin No.	Volts	Pin No.	Volts
1	2.0	17	-0.1 ~ -0.3	33	2.0	49	2.0
2	NC	18	-2.0	34	3.3 ~ 4.1	50	2.0
3	-2.4 ~ -2.3	19	-2.0	35	2.0	51	0
4	-2.4 ~ -2.3	20	1.2	36	0	52	2.0
5	-2.4 ~ -2.3	21	1.1	37	2.0	53	2.0
6	-2.4 ~ -2.3	22	-0.0 ~ -1.0	38	2.0	54	0
7	-2.4 ~ -2.3	23	0.5 ~ 0.8	39	0	55	2.0
8	-2.4 ~ -2.3	24	0.8 ~ 1.1	40	0	56	2.2
9	-2.4 ~ -2.3	25	0	41	NC	57	2.2
10	-2.4 ~ -2.3	26	NC	42	NC	58	0
11	-2.4 ~ -2.3	27	0.5 ~ 0.4	43	2.0	59	0
12	2.0	28	-5.0 ~ -3.3	44	2.0	60	NC
13	2.0	29	-1.0 ~ -1.0	45	0	61	0
14	0	30	-1.2 ~ -1.3	46	2.0	62	0
15	NC	31	0	47	2.0	63	0
16	-2.3	32	2.0	48	5.1 ~ 3.0	64	0

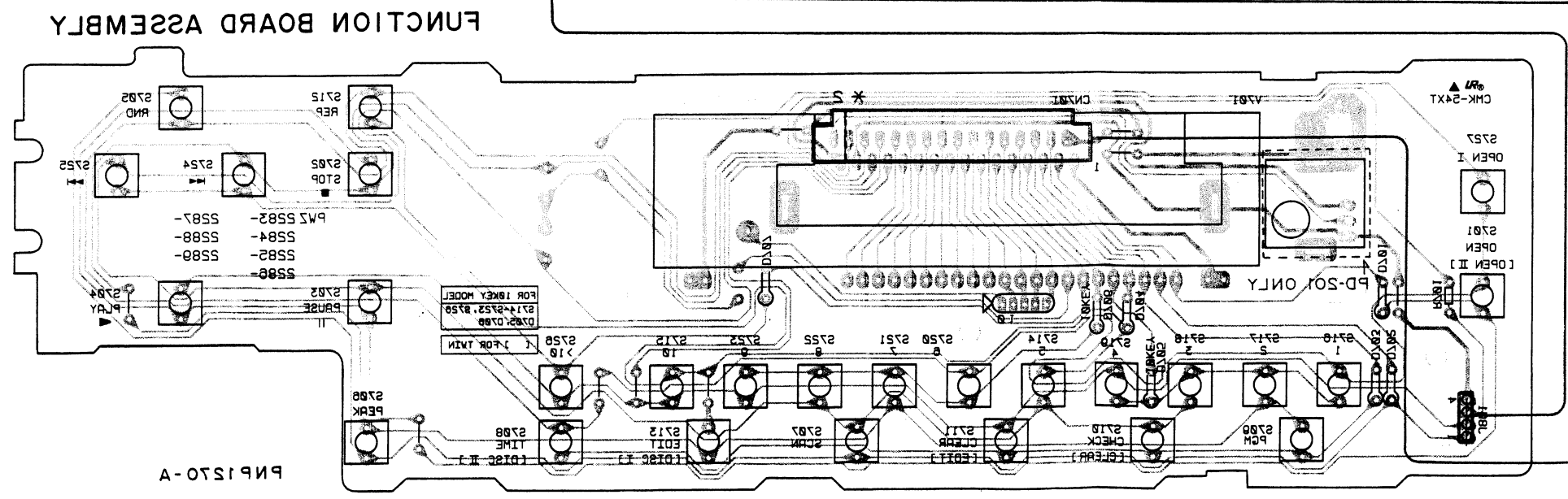

FUNCTION BOARD ASSEMBLY

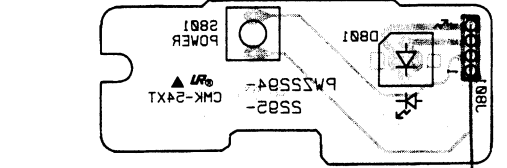

SWITCH BOARD ASSEMBLY

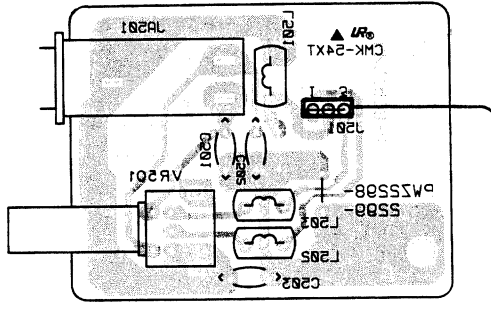

HEADPHONE BOARD ASSEMBLY

A

B

C

D

● View from component side

A

B

C

D

P.C.B. pattern diagram indication	Corresponding part symbol	Part name	P.C.B. pattern diagram indication	Corresponding part symbol	Part name
		Transistor			Ceramic capacitor
		FET			Mylar capacitor
		Diode			Styrol capacitor
		Zener diode			Electrolytic capacitor (Non polarized)
		LED			Electrolytic capacitor (Noiseless)
		Varactor			Electrolytic capacitor (Polarized)
		Tact switch			Power capacitor
		Inductor			Semi-fixed resistor
		Coil			Resistor array
		Transformer			Resistor
		Filter			Resonator
					Thermistor

1. This P.C.B. connection diagram is viewed from the parts mounted side.
2. The parts which have been mounted on the board can be replaced with those shown with the corresponding wiring symbols listed in the above Table.
3. The capacitor terminal marked with shows negative terminal.
4. The diode marked with shows cathode side.
5. The transistor terminal marked with shows emitter.

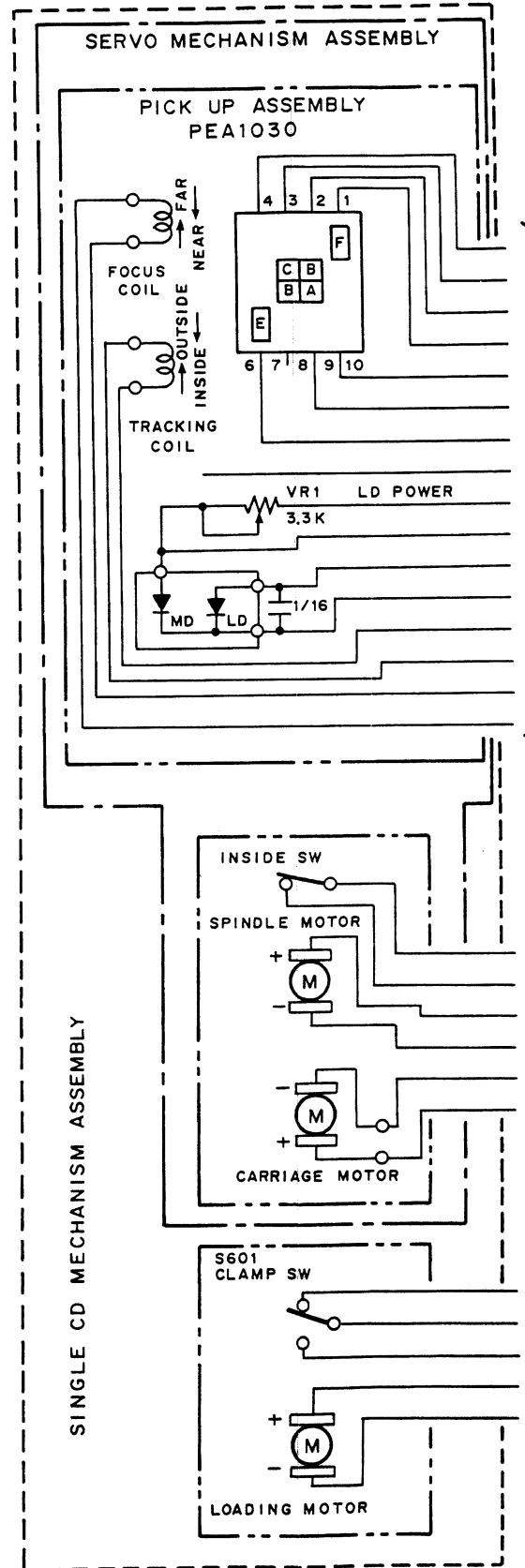

MOTHER BOARD ASSEMBLY
(PWM1657; PD-201)
(PWM1653; PD-101)

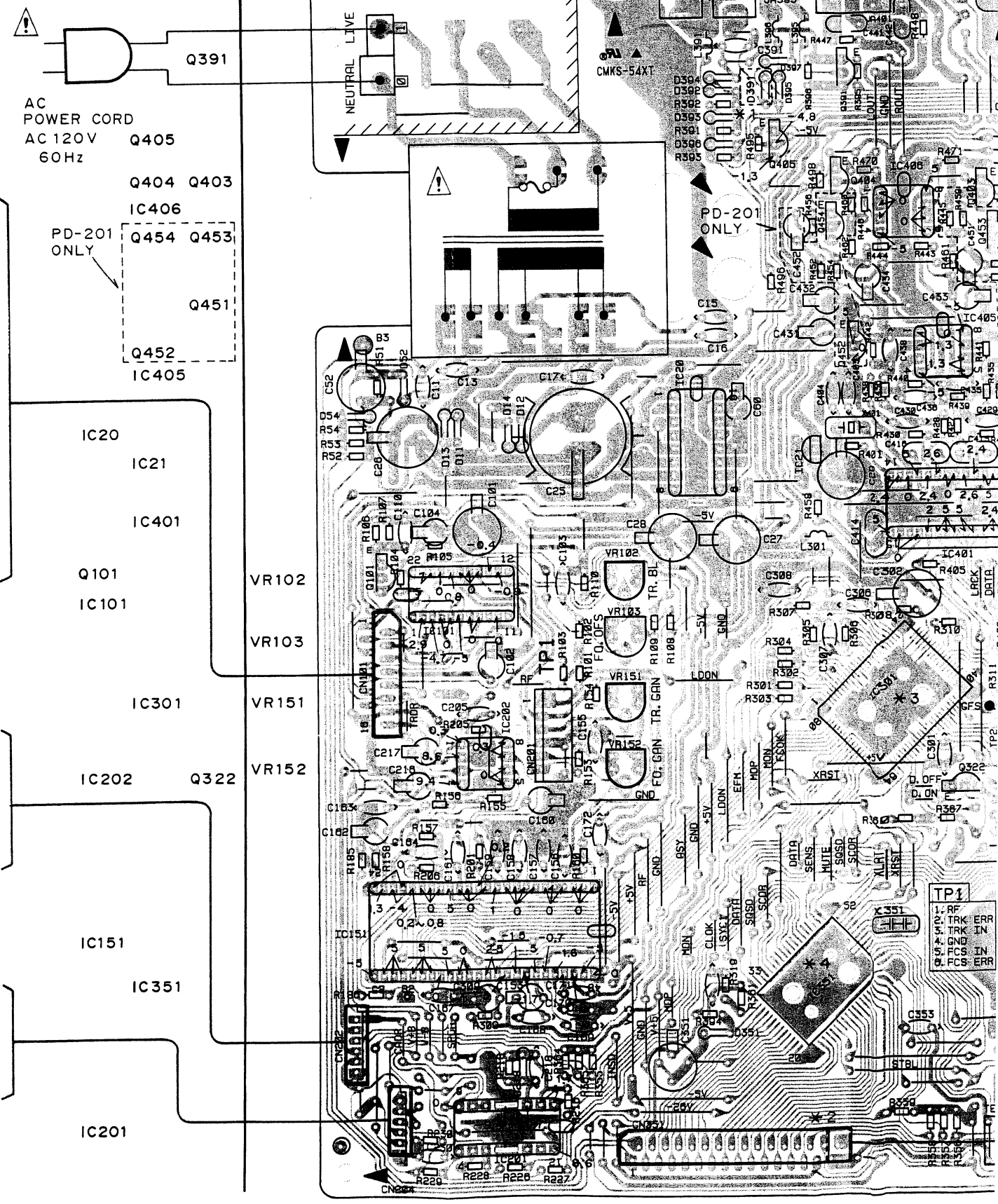

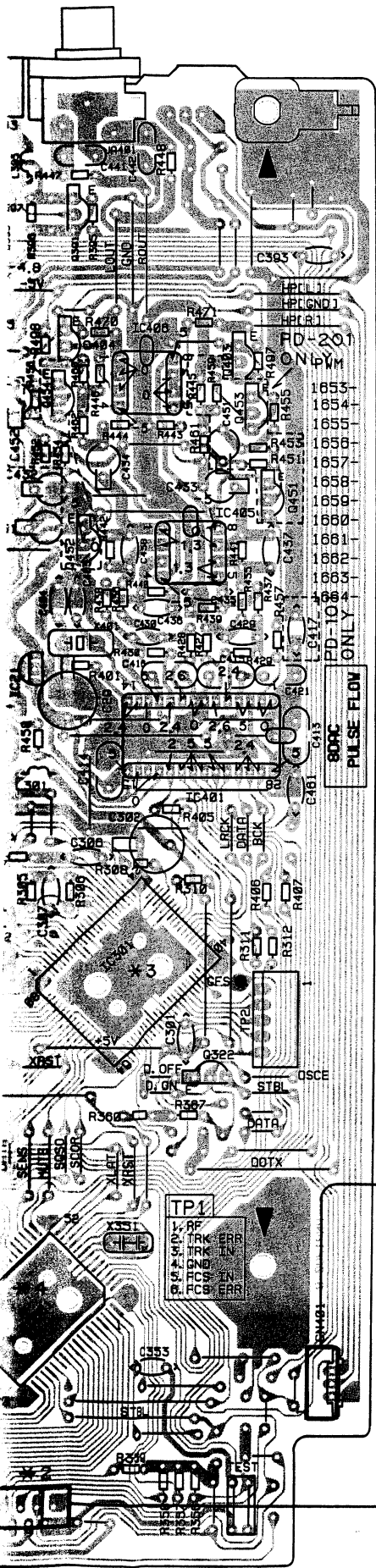

* 3
IC301 (CXD2500AQ)

Pin No.	Volts	Pin No.	Volts	Pin No.	Volts	Pin No.	Volts
1	5.0	21	0	41	NC	61	NC
2	NC	22	2.5	42	5.0	62	NC
3	5.0	23	5.0	43	NC	63	NC
4	2.6	24	2.5	44	NC	64	NC
5	NC	25	NC	45	NC	65	0
6	5.0	26	0	46	4.4	66	3.3 ~ 4.6
7	NC	27	2.5	47	0	67	5.0
8	NC	28	NC	48	0	68	0
9	0	29	0	49	0 ~ 0.3	69	2.1 ~ 3.0
10	0	30	NC	50	NC	70	5.0
11	NC	31	1.3 ~ 2.2	51	NC	71	5.0
12	0	32	2.5	52	0	72	5.0
13	NC	33	5.0	53	2.5	73	5.0
14	NC	34	2.5	54	NC	74	5.0
15	NC	35	NC	55	0	75	5.0
16	NC	36	NC	56	NC	76	0
17	0	37	NC	57	NC	77	5.0
18	2.5	38	NC	58	NC	78	5.0
19	2.4	39	NC	59	0	79	5.0
20	2.4	40	NC	60	NC	80	0

* 4
IC351 (PD4394A)

Pin No.	Volts	Pin No.	Volts	Pin No.	Volts	Pin No.	Volts
1	5.0	17	-9.1 ~ -9.3	33	5.0	49	5.0
2	NC	18	-26.0	34	3.3 ~ 4.7	50	5.0
3	-24 ~ -24.3	19	-5.0	35	5.0	51	0
4	-24 ~ -24.3	20	1.2	36	0	52	5.0
5	-24 ~ -24.3	21	1.1	37	5.0	53	5.0
6	-24 ~ -24.3	22	-9.0 ~ -12.0	38	5.0	54	0
7	-24 ~ -24.3	23	0.2 ~ 0.8	39	0	55	5.0
8	-24 ~ -24.3	24	0.6 ~ 1.1	40	0	56	2.5
9	-24 ~ -24.3	25	0	41	NC	57	2.5
10	-24 ~ -24.3	26	NC	42	NC	58	0
11	-24 ~ -24.3	27	0.2 ~ 0.4	43	5.0	59	0
12	5.0	28	-2.0 ~ -3.3	44	5.0	60	NC
13	5.0	29	-14.0 ~ -17.0	45	0	61	0
14	0	30	-11.5 ~ -17.3	46	5.0	62	0
15	NC	31	0	47	5.0	63	0
16	-23.8	32	5.0	48	2.1 ~ 3.0	64	0

HEADPHONE BOARD ASSEMBLY

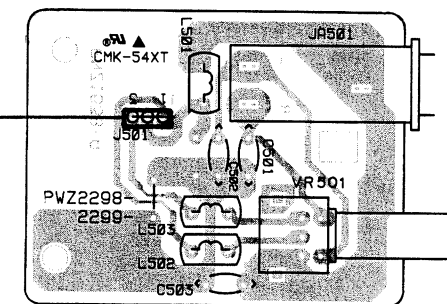

SWITCH BOARD ASSEMBLY

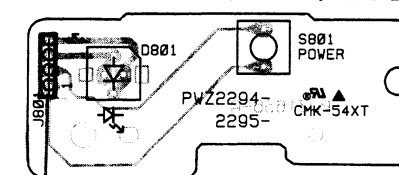

FUNCTION BOARD ASSEMBLY

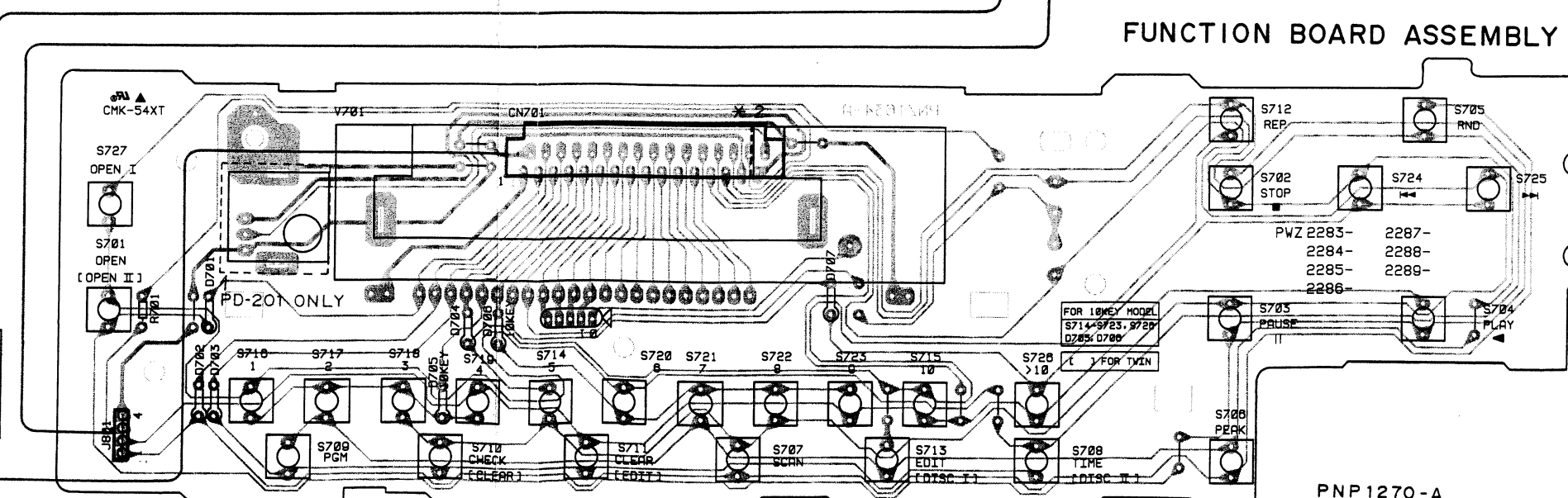

* 1	D391
PD-201	USED
PD-101	SHORT

* 2	PD-101	PD-201
CN351	HLEM30S-1	HLEM32S-1
CN701	HLEM30R-1	HLEM32R-1

PNP1290-B

PNP1270-A

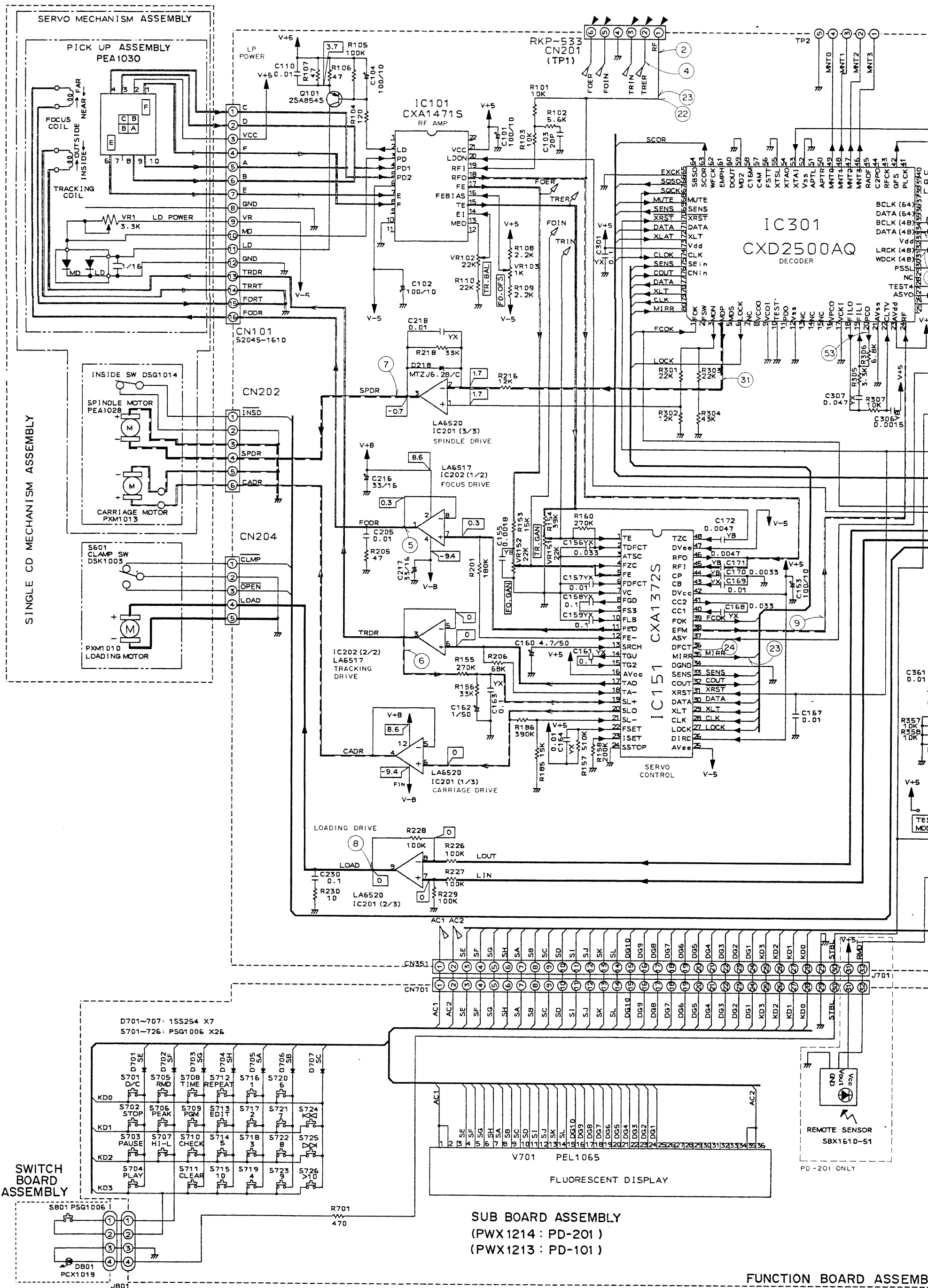

SERVO MECHANISM ASSEMBLY

PICK UP ASSEMBLY
PEA1030

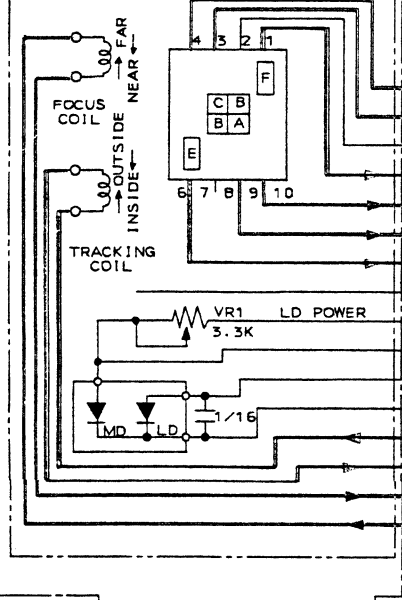

SINGLE CD MECHANISM ASSEMBLY

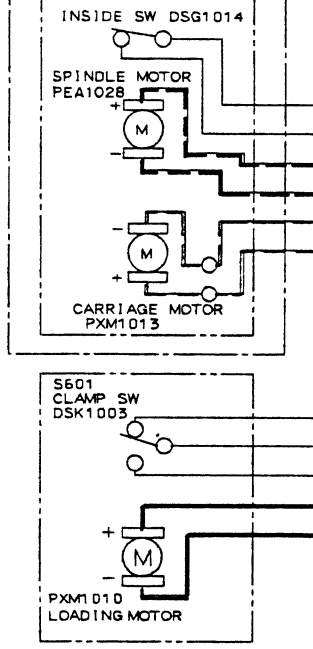

SWITCH BOARD ASSEMBLY

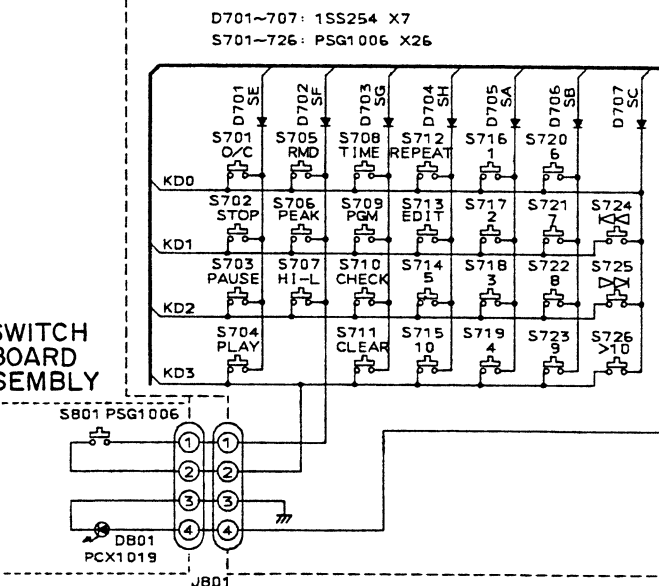

SUB BOARD ASSEMBLY
(PWX1214 : PD-201)
(PWX1213 : PD-101)

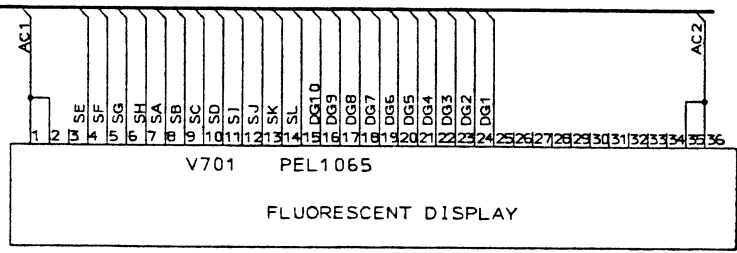

FUNCTION BOARD ASSEMBLY

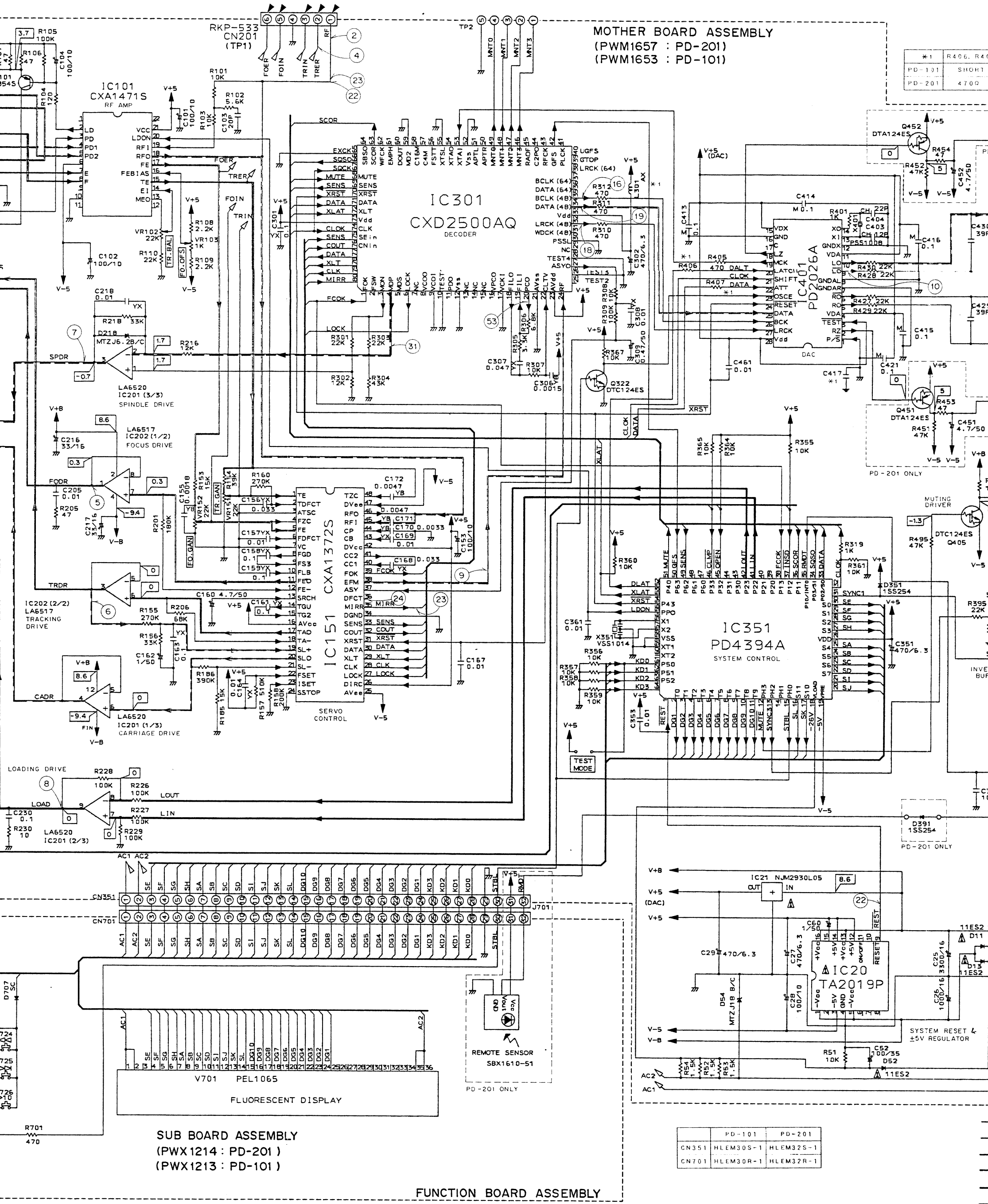

MOTHER BOARD ASSEMBLY
(PWM1657 : PD-201)
(PWM1653 : PD-101)

*1	R406, R407
PD-191	SHORT
PD-201	4700

SUB BOARD ASSEMBLY
(PWX1214 : PD-201)
(PWX1213 : PD-101)

	PD-101	PD-201
CN351	HLEM30S-1	HLEM32S-1
CN701	HLEM30R-1	HLEM32R-1

FUNCTION BOARD ASSEMBLY

V701 PEL1065
FLUORESCENT DISPLAY

REMOTE SENSOR
SBX1610-51
PD-201 ONLY

SYSTEM RESET & +5V REGULATOR

MOTHER BOARD ASSEMBLY
(PWM1657 : PD-201)
(PWM1653 : PD-101)

*1	R406, R407	C417	L301	R445, R446
PD-101	SHORT	0.01	SHORT	4700
PD-201	4700	OPEN	1uH	2700

*2	C433, C434	IC405
PD-101	220/25	NJM45580
PD-201	PCH1107	NJM4565D

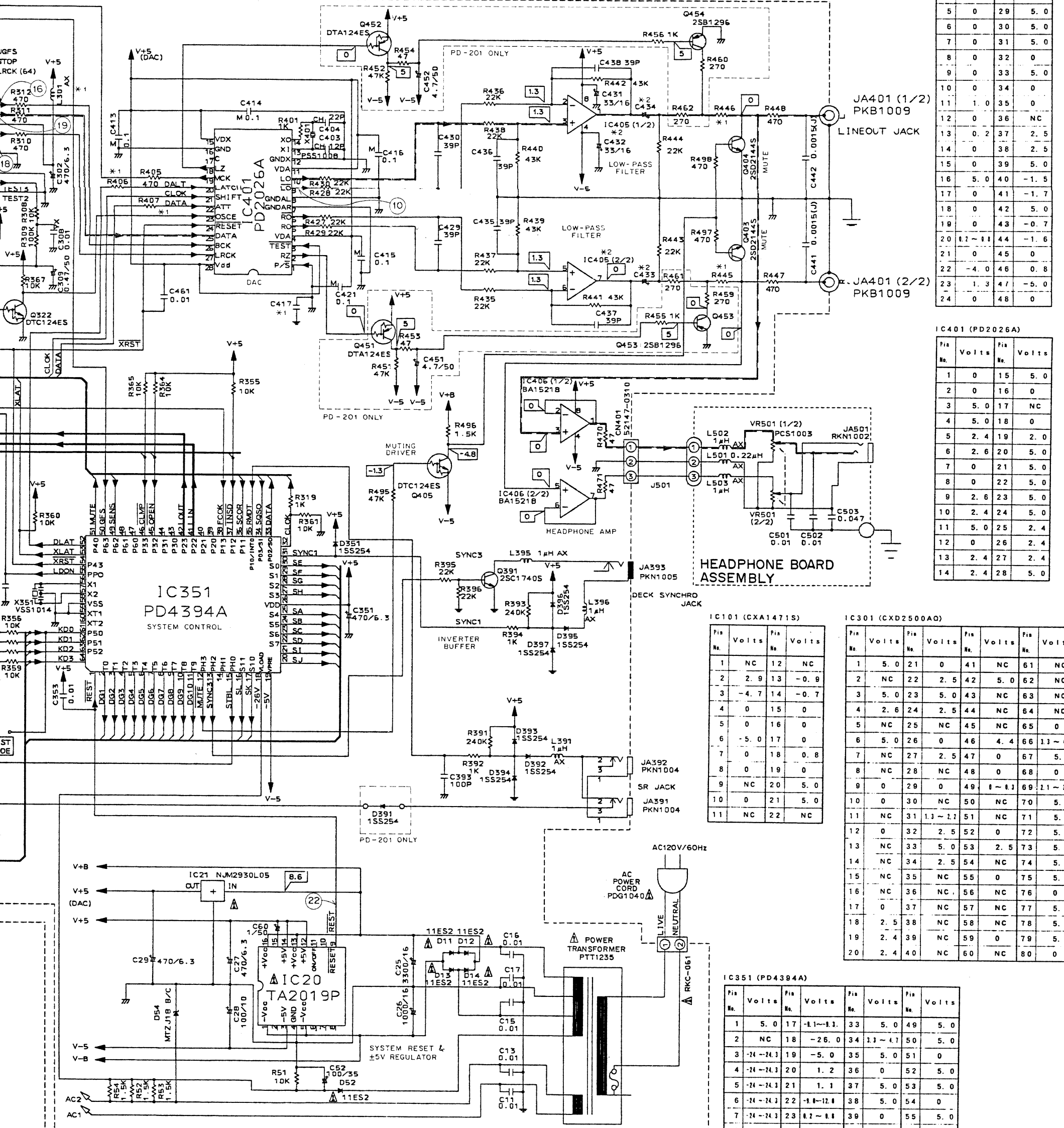

IC151 (CXA1372S)

Pin No.	Volts	Pin No.	Volts
1	0	25	-5.0
2	0	26	5.0
3	0	27	5.0
4	0	28	5.0
5	0	29	5.0
6	0	30	5.0
7	0	31	5.0
8	0	32	0
9	0	33	5.0
10	0	34	0
11	1.0	35	0
12	0	36	NC
13	0.2	37	2.5
14	0	38	2.5
15	0	39	5.0
16	5.0	40	-1.5
17	0	41	-1.7
18	0	42	5.0
19	0	43	-0.7
20	0.2	44	-1.6
21	0	45	0
22	-4.0	46	0.8
23	1.3	47	-5.0
24	0	48	0

IC401 (PD2026A)

Pin No.	Volts	Pin No.	Volts
1	0	15	5.0
2	0	16	0
3	5.0	17	NC
4	5.0	18	0
5	2.4	19	2.0
6	2.6	20	5.0
7	0	21	5.0
8	0	22	5.0
9	2.6	23	5.0
10	2.4	24	5.0
11	5.0	25	2.4
12	0	26	2.4
13	2.4	27	2.4
14	2.4	28	5.0

IC101 (CXA1471S)

Pin No.	Volts	Pin No.	Volts
1	NC	12	NC
2	2.9	13	-0.9
3	-4.7	14	-0.7
4	0	15	0
5	0	16	0
6	-5.0	17	0
7	0	18	0.8
8	0	19	0
9	NC	20	5.0
10	0	21	5.0
11	NC	22	NC

IC301 (CXD2500A0)

Pin No.	Volts	Pin No.	Volts	Pin No.	Volts	Pin No.	Volts
1	5.0	21	0	41	NC	61	NC
2	NC	22	2.5	42	5.0	62	NC
3	5.0	23	5.0	43	NC	63	NC
4	2.6	24	2.5	44	NC	64	NC
5	NC	25	NC	45	NC	65	0
6	5.0	26	0	46	4.4	66	1.1~1.6
7	NC	27	2.5	47	0	67	5.0
8	NC	28	NC	48	0	68	0
9	0	29	0	49	1.1~1.3	69	1.1~1.6
10	0	30	NC	50	NC	70	5.0
11	NC	31	1.1~1.2	51	NC	71	5.0
12	0	32	2.5	52	0	72	5.0
13	NC	33	5.0	53	2.5	73	5.0
14	NC	34	2.5	54	NC	74	5.0
15	NC	35	NC	55	0	75	5.0
16	NC	36	NC	56	NC	76	0
17	0	37	NC	57	NC	77	5.0
18	2.5	38	NC	58	NC	78	5.0
19	2.4	39	NC	59	0	79	5.0
20	2.4	40	NC	60	NC	80	0

IC351 (PD4394A)

Pin No.	Volts	Pin No.	Volts	Pin No.	Volts	Pin No.	Volts	
1	5.0	17	-1.1~1.1	33	5.0	49	5.0	
2	NC	18	-26.0	34	1.1~1.7	50	5.0	
3	-24	-24.3	19	-5.0	35	5.0	51	0
4	-24	-24.3	20	1.2	36	0	52	5.0
5	-24	-24.3	21	1.1	37	5.0	53	5.0
6	-24	-24.3	22	-1.0~12.8	38	5.0	54	0
7	-24	-24.3	23	0.2~0.8	39	0	55	5.0
8	-24	-24.3	24	0.1~1.1	40	0	56	2.5
9	-24	-24.3	25	0	41	NC	57	2.5
10	-24	-24.3	26	NC	42	NC	58	0
11	-24	-24.3	27	0.2~0.4	43	5.0	59	0
12	5.0	28	-2.8~1.3	44	5.0	60	NC	
13	5.0	29	-14.0~17.1	45	0	61	0	
14	0	30	-11.5~11.3	46	5.0	62	0	
15	NC	31	0	47	5.0	63	0	
16	-23.8	32	5.0	48	2.1~1.1	64	0	

	PD-101	PD-201
CN351	HLEM30S-1	HLEM32S-1
CN701	HLEM30R-1	HLEM32R-1

- :Focus servo loop
- - - :Signal route
- :Tracking servo loop
- - - :Carriage servo loop
- :Loading motor route
- - - :Spindle motor route
- ▶ :Measurement point

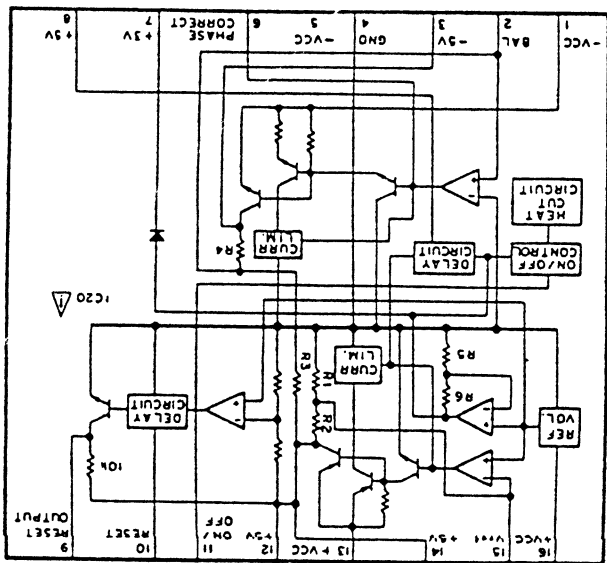

IC20:TA2019P

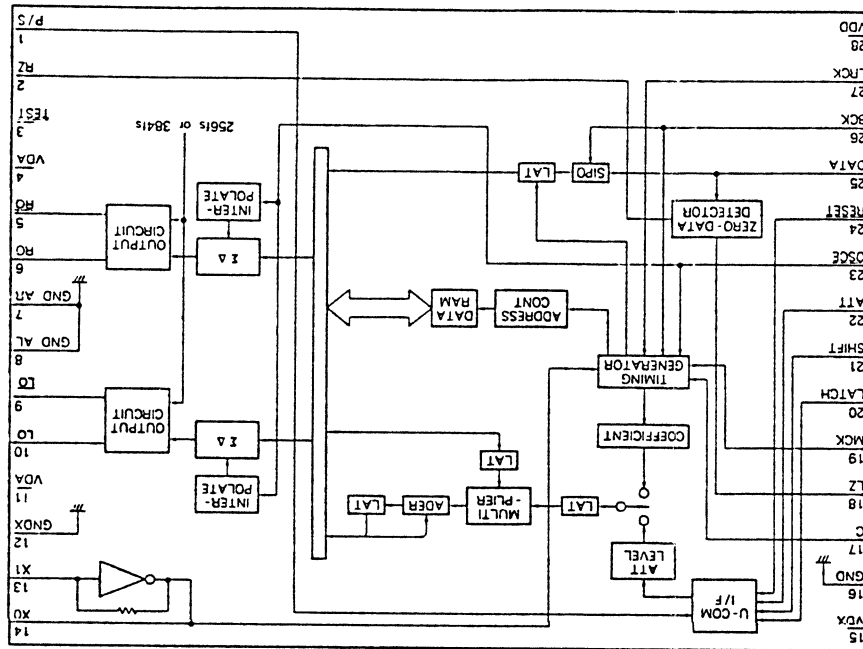

IC401:PD2026A

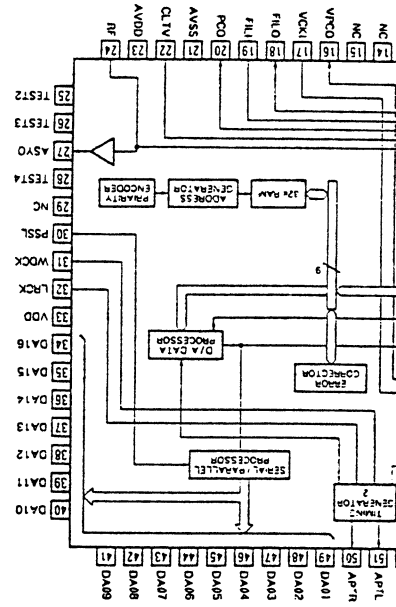

Wave Forms

Note: The encircled numbers denote measuring points in the schematic diagram.

*1 50T-JUMP: After switching to the pause mode, press the manual search key.

*2 FOCUS-IN: Press the key without loading a disc.

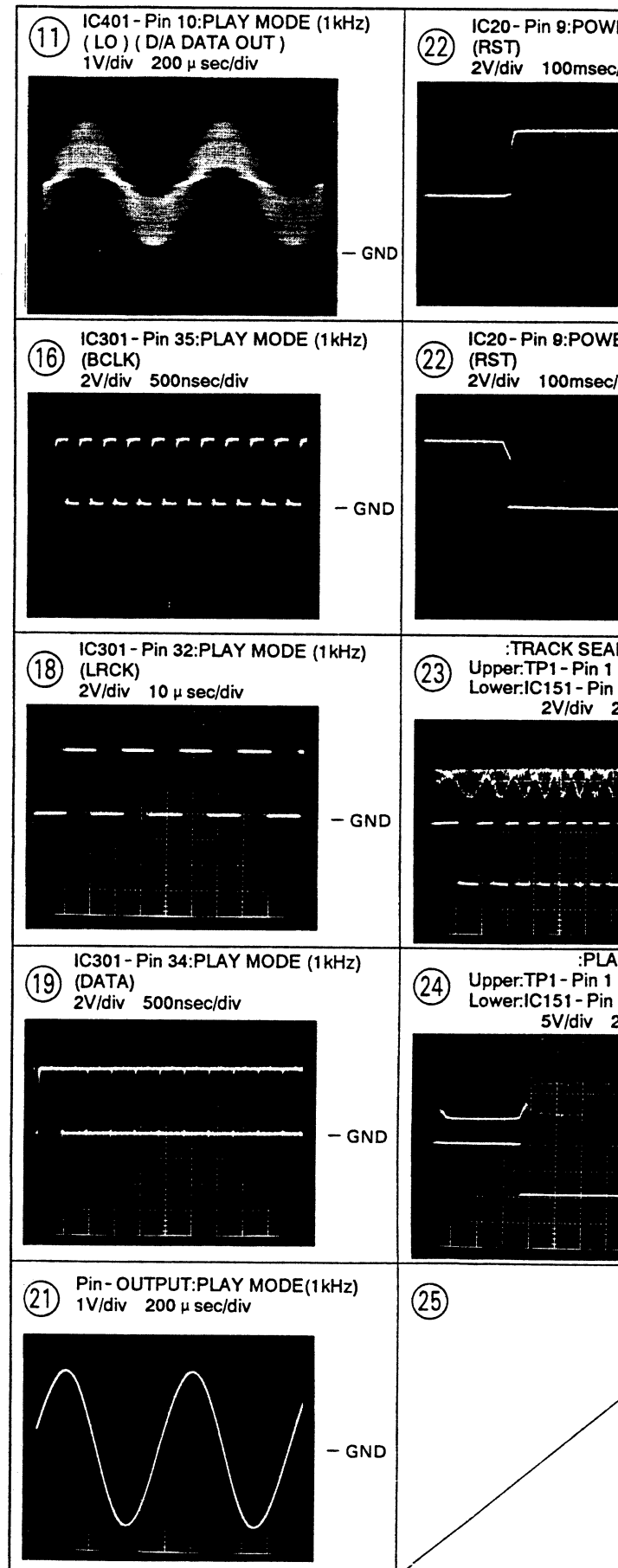
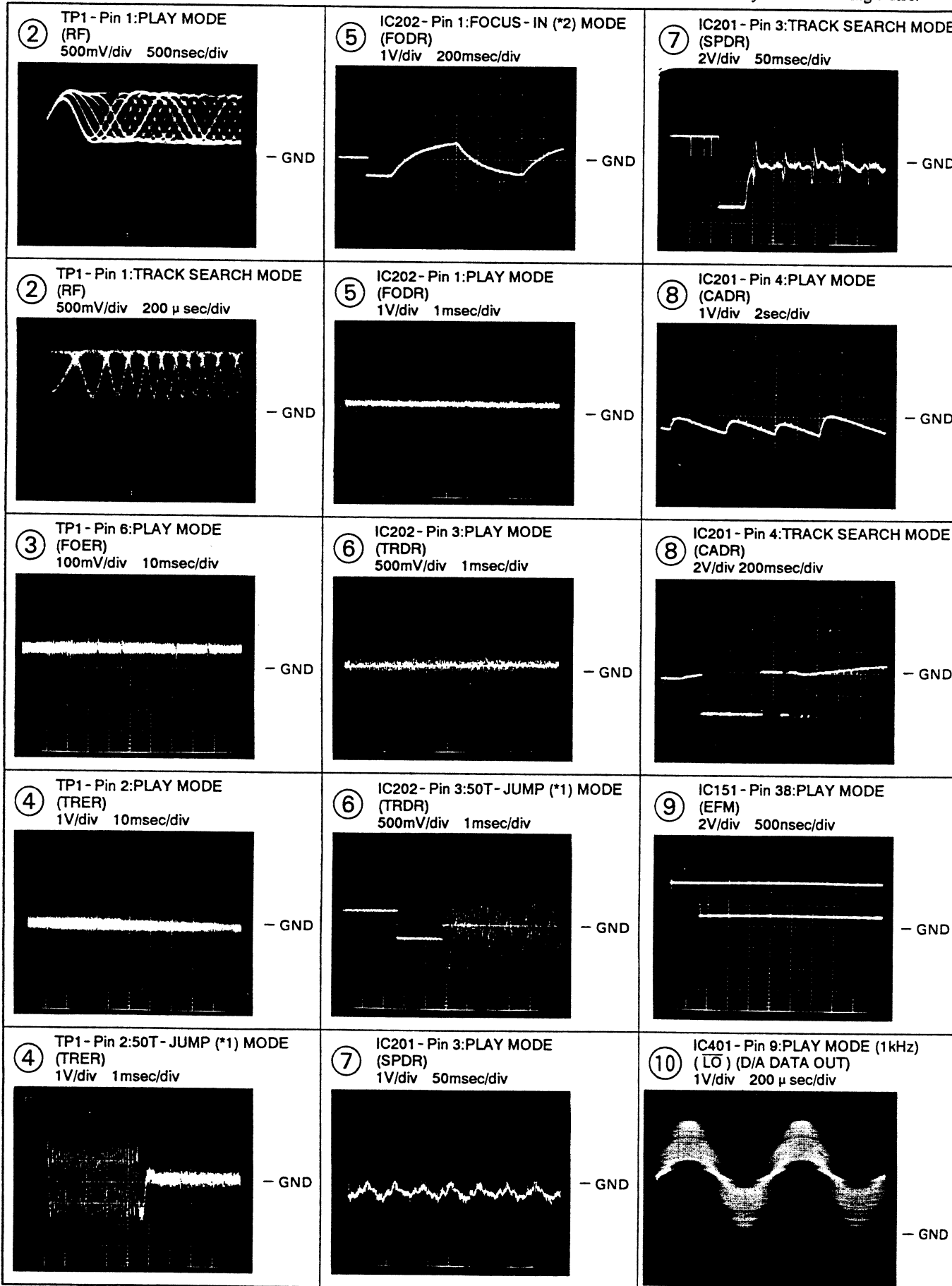

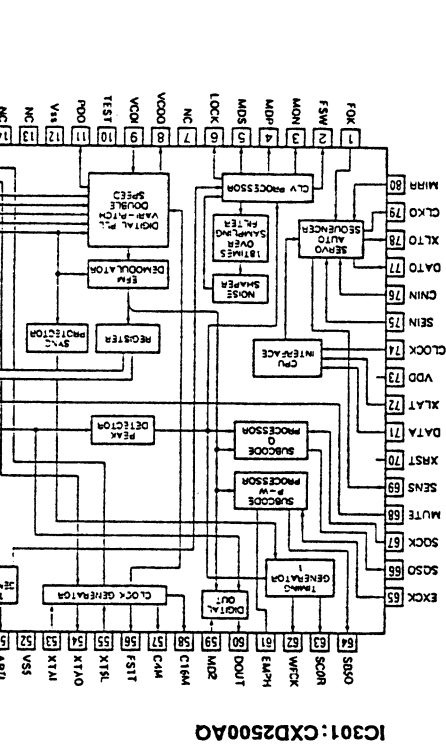

IC301: CXD2500AQ

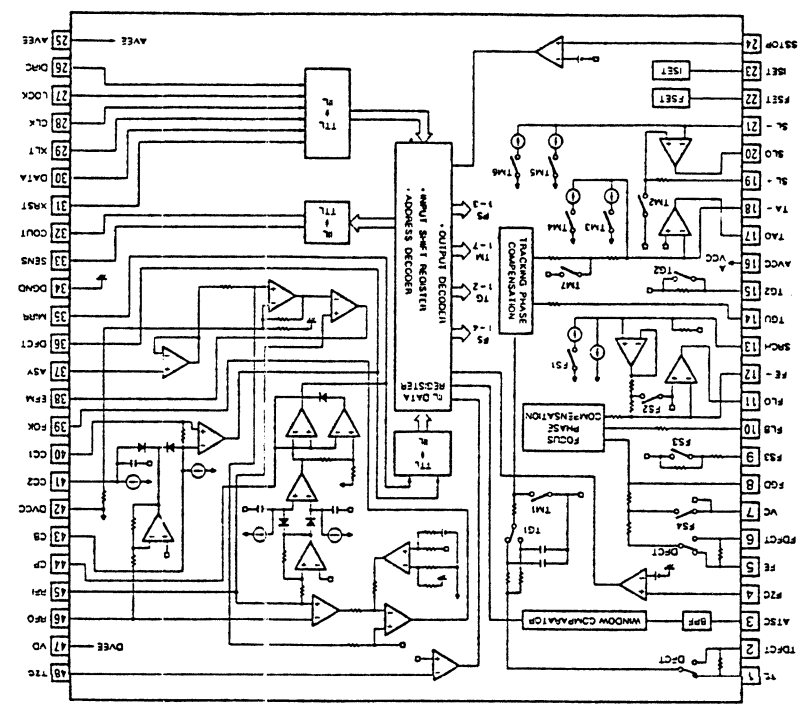

IC151: CXA1372S

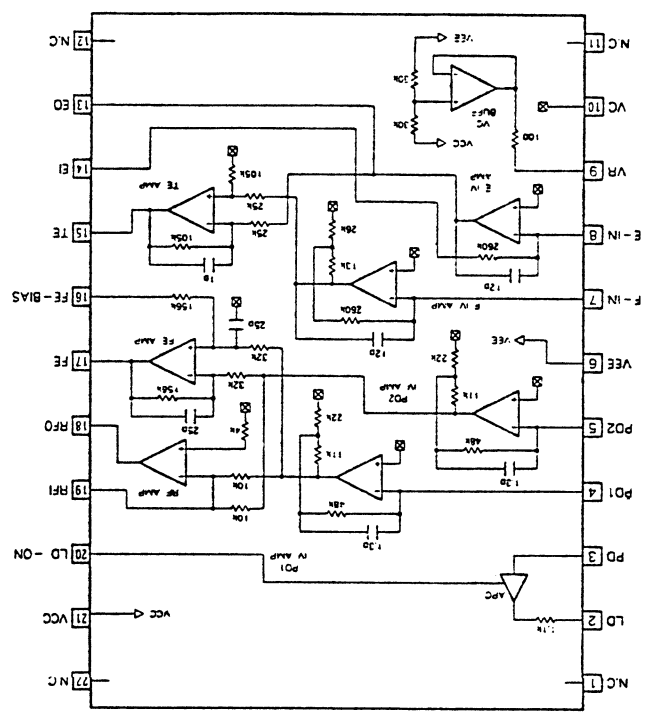

IC101: CXA1471S

● IC BLOCK DIAGRAMS

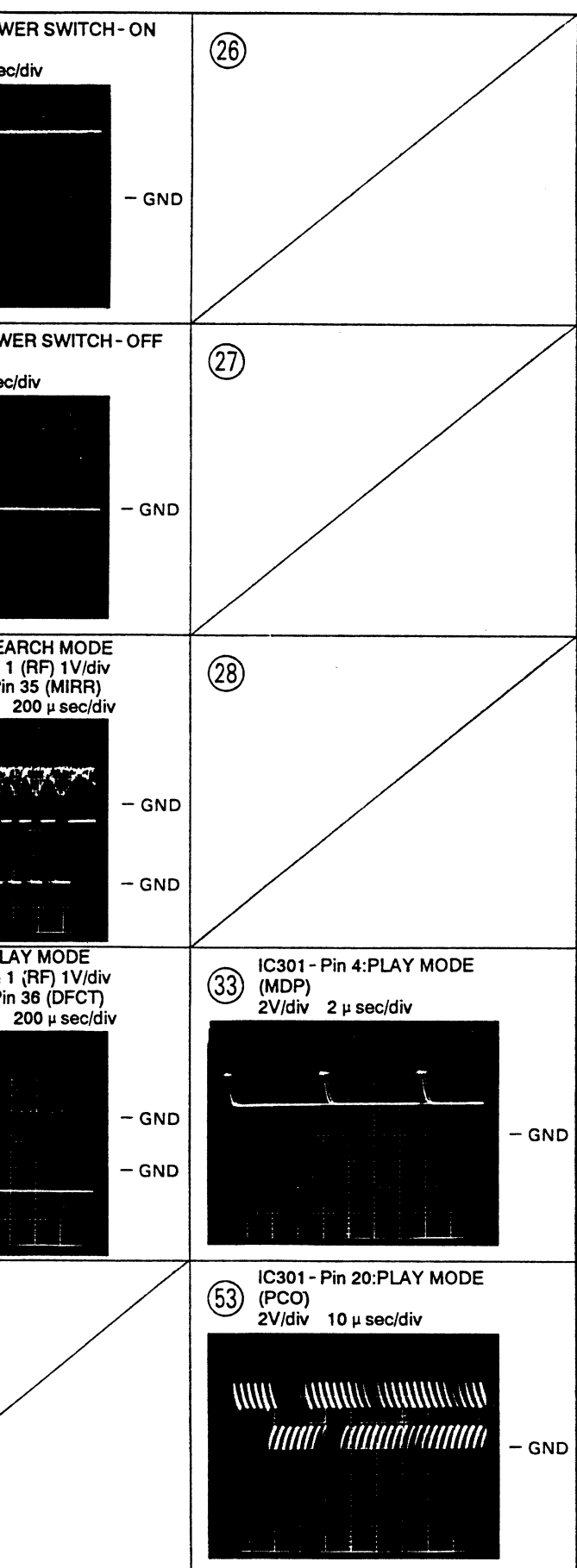

5. PCB PARTS LIST

NOTES:

- Parts without part number cannot be supplied.
- Parts marked with "⊙" are not always kept in stock. Their delivery time may be longer than usual or they may be unavailable.
- The Δ mark found on some component parts indicates the importance of the safety factor of the part. Therefore, when replacing, be sure to use parts of identical designation.
- When ordering resistors, first convert resistance values into code form as shown in the following examples.
 Ex.1 When there are 2 effective digits (any digit apart from 0), such as 560 ohm and 47k ohm (tolerance is shown by J=5%, and K=10%)
 560 Ω → 56 × 10¹ → 561 RD1/4PS 561J
 47k Ω → 47 × 10³ → 473 RD1/4PS 473J
 0.5 Ω → 0R5 RN2H 0R5K
 1 Ω → 010 RS1P 010K
 Ex.2 When there are 3 effective digits (such as in high precision metal film resistors).
 5.62k Ω → 562 × 10¹ → 5621 RN1/4SR 5621F

Mark	No.	Description	Part No.	Mark	No.	Description	Part No.
LIST OF ASSEMBLIES				CAPACITORS			
⊙		MOTHER BOARD ASSEMBLY	PWM1657		C11	CERAMIC CAPACITOR	CKCYF103Z50
⊙		SUB BOARD ASSEMBLY	PWX1214		C13	CERAMIC CAPACITOR	CKCYF103Z50
		FUNCTION BOARD ASSEMBLY			C15-17	CERAMIC CAPACITOR	CKCYF103Z50
		SW PCB ASSEMBLY			C25	ELECTR. CAPACITOR	CEAS332M16
		HEADPHONE PCB ASSEMBLY			C26	ELECTR. CAPACITOR	CEAS102M16
⊙ MOTHER BOARD ASSEMBLY (PWM1657)					C27	ELECTR. CAPACITOR	CEAS471M6R3
SEMICONDUCTORS					C28	ELECTR. CAPACITOR	CEAS101M10
Δ	IC20	REGULATOR IC	TA2019P		C29	ELECTR. CAPACITOR	CEAS471M6R3
	IC21	REGULATOR IC	NJM2930L05		C52	ELECTR. CAPACITOR	CEAS101M35
	IC101	PRE AMP IC	CXA1471S		C60	ELECTR. CAPACITOR	CEAS010M50
	IC151	SERVO IC	CXA1372S		C101, 102	ELECTR. CAPACITOR	CEAS101M10
Δ	IC201	POWER OP-AMP IC	LA6520		C103	CERAMIC CAPACITOR	CCCCH200J50
	IC202	POWER OP-AMP IC	LA6517		C104	ELECTR. CAPACITOR	CEAS101M10
	IC301	EFM DEMODULATION IC (MDP)	CXD2500AQ		C110	CERAMIC CAPACITOR	CKCYF103Z50
	IC351	MICROCOMPUTER IC	PD4394A		C153	ELECTR. CAPACITOR	CEAS101M10
	IC401	D/A CONVERTER IC	PD2026A		C155	CERAMIC CAPACITOR	CKCYB182K50
	IC405	OP-AMP IC	NJM4565D-D		C156	CERAMIC CAPACITOR	CGCYX333K25
	IC406	OP-AMP IC	BA15218		C157	CERAMIC CAPACITOR	CGCYX103K25
	Q101	TRANSISTOR	2SA854S		C158, 159	CERAMIC CAPACITOR	CGCYX104K25
	Q322	TRANSISTOR	DTC124ES		C160	ELECTR. CAPACITOR	CEAS471M50
	Q391	TRANSISTOR	2SC1740S		C161	CERAMIC CAPACITOR	CGCYX104K25
	Q403, 404	TRANSISTOR	2SD2144S		C162	ELECTR. CAPACITOR	CEAS010M50
	Q405	TRANSISTOR	DTC124ES		C163	CERAMIC CAPACITOR	CGCYX104K25
	Q451, 452	TRANSISTOR	DTA124ES		C164	CERAMIC CAPACITOR	CGCYX103K25
	Q453, 454	TRANSISTOR	2SB1296		C167	CERAMIC CAPACITOR	CKCYF103Z50
Δ	D11-14	DIODE	11ES2		C168	CERAMIC CAPACITOR	CGCYX333K25
Δ	D52	DIODE	11ES2		C169	CERAMIC CAPACITOR	CGCYX103K25
	D54	ZENNER DIODE	MTZJ18B		C170	CERAMIC CAPACITOR	CKCYB332K50
	D218	ZENNER DIODE	MTZJ6.2B		C171, 172	CERAMIC CAPACITOR	CKCYB472K50
	D351	DIODE	1SS254		C205	CERAMIC CAPACITOR	CKCYF103Z50
	D391-397	DIODE	1SS254		C216, 217	ELECTR. CAPACITOR	CEAS330M16
COILS/TRANSFORMERS					C218	CERAMIC CAPACITOR	CGCYX103K25
	L301	AXIAL INDUCTOR	LAU010K		C230	CERAMIC CAPACITOR	CGCYX104K25
	L391	AXIAL INDUCTOR	LAU010K		C301	CERAMIC CAPACITOR	CGCYX104K25
	L395, 396	AXIAL INDUCTOR	LAU010K		C302	ELECTR. CAPACITOR	CEAS471M6R3
					C306	CERAMIC CAPACITOR	CKCYB152K50
					C307	CERAMIC CAPACITOR	CGCYX473K25

Mark	No.	Description	Part No.
C308		CERAMIC CAPACITOR	CGCYX103K25
C309		ELECTR. CAPACITOR	CEASR47M50
C351		ELECTR. CAPACITOR	CEAS471M6R3
C353		CERAMIC CAPACITOR	CKCYF103Z50
C361		CERAMIC CAPACITOR	CKCYF103Z50
C393		CERAMIC CAPACITOR	CCCSL101J50
C403		CERAMIC CAPACITOR	CCCCH120J50
C404		CERAMIC CAPACITOR	CCCCH220J50
C413-416		FILM CAPACITOR	PCL1032
C421		FILM CAPACITOR	PCL1032
C429, 430		CERAMIC CAPACITOR	CCCCH390J50
C431, 432		ELECTR. CAPACITOR	CEAS330M16
C433, 434		CAPACITOR (ALUMINUM)	PCH1107
C435-438		CERAMIC CAPACITOR	CCCCH390J50
C441, 442		FILM CAPACITOR	PCL1030
C451, 452		ELECTR. CAPACITOR	CEAS4R7M50
C461		CERAMIC CAPACITOR	CKCYF103Z50
RESISTORS			
R51-54		CARBONFILM RESISTOR	RD1/6PM□□□J
R101-110		CARBONFILM RESISTOR	RD1/6PM□□□J
R153-158		CARBONFILM RESISTOR	RD1/6PM□□□J
R160		CARBONFILM RESISTOR	RD1/6PM□□□J
R185, 186		CARBONFILM RESISTOR	RD1/6PM□□□J
R201		CARBONFILM RESISTOR	RD1/6PM□□□J
R205, 206		CARBONFILM RESISTOR	RD1/6PM□□□J
R216		CARBONFILM RESISTOR	RD1/6PM□□□J
R218		CARBONFILM RESISTOR	RD1/6PM□□□J
R226-230		CARBONFILM RESISTOR	RD1/6PM□□□J
R301-312		CARBONFILM RESISTOR	RD1/6PM□□□J
R319		CARBONFILM RESISTOR	RD1/6PM□□□J
R355-361		CARBONFILM RESISTOR	RD1/6PM□□□J
R364, 365		CARBONFILM RESISTOR	RD1/6PM□□□J
R367		CARBONFILM RESISTOR	RD1/6PM□□□J
R391-396		CARBONFILM RESISTOR	RD1/6PM□□□J
R401		CARBONFILM RESISTOR	RD1/6PM□□□J
R405-407		CARBONFILM RESISTOR	RD1/6PM□□□J
R427-430		CARBONFILM RESISTOR	RD1/6PM□□□J
R435-448		CARBONFILM RESISTOR	RD1/6PM□□□J
R451-462		CARBONFILM RESISTOR	RD1/6PM□□□J
R470, 471		CARBONFILM RESISTOR	RD1/6PM□□□J
R495-498		CARBONFILM RESISTOR	RD1/6PM□□□J
VR102		VR	RCP1046
VR103		VR	RCP1044
VR151, 152		VR	RCP1046
OTHERS			
CN101		CONNECTOR	52045-1610
CN351		CONNECTOR	HLEM32S-1
JA391, 392		JACK/12V	PKN1004
JA393		JACK	PKN1005
JA401		JACK	PKB1009
X351		CERAMIC RESONATOR	VSS1014
X401		XTAL RES (OSC)	PSS1008

FUNCTION BOARD ASSEMBLY

Mark	No.	Description	Part No.
SEMICONDUCTORS			
		D701-707 DIODE	1SS254
SWITCHES			
		S701-726 SWITCH	PSG1006
		REMOTE SENSOR	SBX1610-51
RESISTORS			
		R701 CARBONFILM RESISTOR	RD1/6PM□□□J
OTHERS			
		CN701 CONNECTOR	HLEM32R-1
		V701 FL INDICATOR TUBE	PEL1065

SW PCB ASSEMBLY

Mark	No.	Description	Part No.
SEMICONDUCTORS			
		D801 LED	PCX1019
SWITCHES			
		S801 SWITCH	PSG1006

HEADPHONE PCB ASSEMBLY

Mark	No.	Description	Part No.
COILS/TRANSFORMERS			
		L501 AXIAL COIL	LAUR22K
		L502, 503 AXIAL INDUCTOR	LAU010K
CAPACITORS			
		C501, 502 CERAMIC CAPACITOR	CKCYF103Z50
		C503 CERAMIC CAPACITOR	CKCYF473Z50
RESISTORS			
		VR501 VARIABLE RESISTOR	PCS1003
OTHERS			
		JA501 JACK	RKN1002

6. ADJUSTMENTS

6.1 Adjustment Methods

If a disc player is adjusted incorrectly or inadequately, it may malfunction or not work at all even though there is nothing at all wrong with the pickup or the circuitry. Adjust correctly following the adjustment procedure.

● Adjustment items/verification items and order

Step	Item	Test point	Adjustment location
1	Focus offset adjustment	TP1, Pin 6(FCS. ERR)	VR103(FCS. OFS)
2	Grating adjustment	TP1, Pin 2(TRK. ERR)	Grating adjustment slit
3	Tracking error balance adjustment	TP1, Pin 2(TRK. ERR)	VR102(TRK. BAL)
4	Pickup radial/tangential direction tilt adjustment	TP1, Pin 1(RF)	Radial tilt adjustment screw, Tangential tilt adjustment screw
5	RF level adjustment	TP1, Pin 1(RF)	VR1(RF level)
6	Focus servo loop gain adjustment	TP1, Pin 5(FCS. IN) TP1, Pin 6(FCS. ERR)	VR152(FCS. GAN)
7	Tracking servo loop gain adjustment	TP1, Pin 3(TRK. IN) TP1, Pin 2(TRK. ERR)	VR151(TRK. GAN)
8	Focus error signal verification	TP1, Pin 6(FCS. ERR)	—————

● Abbreviation table

FCS. ERR :Focus Error
 FCS. OFS :Focus Offset
 TRK. ERR :Tracking Error
 TRK. BAL :Tracking Balance
 FCS. GAN :Focus Gain
 TRK. GAN :Tracking Gain
 FCS. IN :Focus In
 TRK. IN :Tracking In

● Measuring instruments and tools

1. Dual trace oscilloscope (10:1 probe)
2. Low-frequency oscillator
3. Test disc (YEDS-7)
4. 12- cm disc (with at least about 70 minutes recording)
5. Low-pass filter (39 kΩ + 0.001 μF)
6. Resistor (100 kΩ)
7. Hexagonal wrench (1.5mm)
8. Standard tools

● Test point and adjustment variable resistor positions

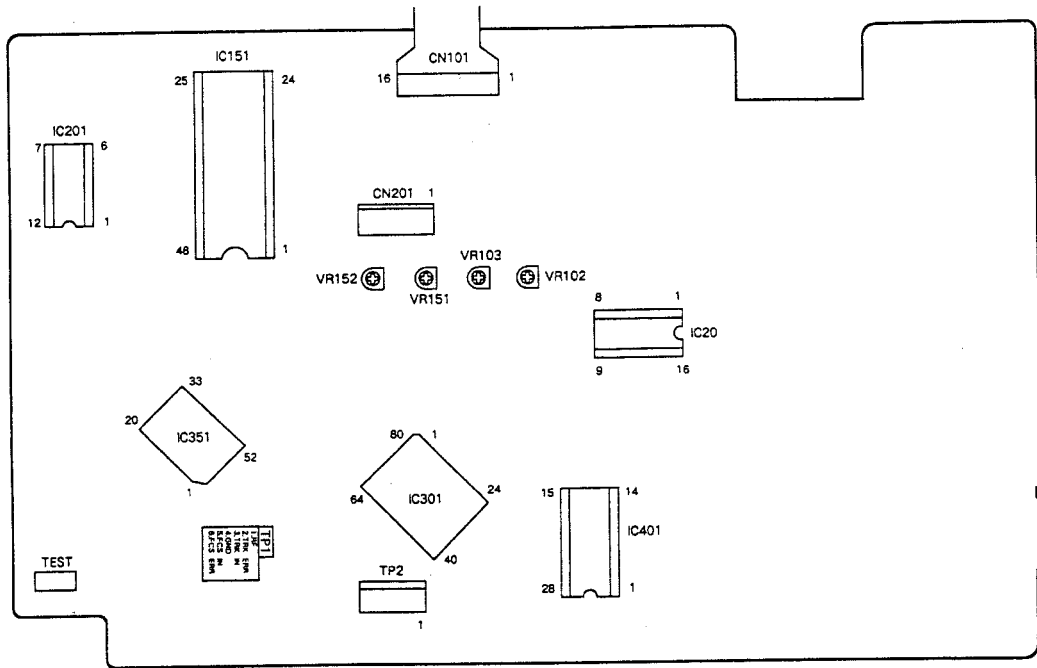

Figure 1 Adjustment Locations

● Notes

1. Use a 10:1 probe for the oscilloscope.
2. All the knob positions (settings) for the oscilloscope in the adjustment procedures are for when a 10:1 probe is used.

● Test mode

These models have a test mode so that the adjustments and checks required for service can be carried out easily. When these models are in test mode, the keys on the front panel work differently from normal. Adjustments and checks can be carried out by operating these keys with the correct procedure. For these models, all adjustments are carried out in test mode.

[Setting these models to test mode]

How to set this model into test mode.

1. Unplug the power cord from the AC socket.
2. Short the test mode jumper wires. (See Figure 1.)
3. Plug the power cord back into the AC socket.

When the test mode is set correctly, the display is different from what it usually is when the power is turned on. If the display is still the same as usual, test mode has not been set correctly, so repeat Steps 1 – 3.

[Release from test mode]

Here is the procedure for releasing the test mode:

1. Press the STOP key and stop all operations.
2. Unplug the power cord from the AC socket.

[Operations of the keys in test mode]

Code	Key name	Function in test mode	Explanation
	PROGRAM	Focus servo close	<p>The laser diode is lit up and the focus actuator is lowered, then raised slowly and the focus servo is closed at the point where the objective lens is focused on the disc.</p> <p>With the player in this state, if you lightly rotate the stopped disc by hand, you can hear the sound the focus servo.</p> <p>If you can hear this sound, the focus servo is operating correctly. If you press this key with no disc mounted, the laser diode lights up, the focus actuator is pulled down, then the actuator is raised and lowered twice and returned to its original position.</p>
▷	PLAY	Spindle servo ON	<p>Starts the spindle motor in the clockwise direction and when the disc rotation reaches the prescribed speed (about 500 rpm at the inner periphery), sets the spindle servo in a closed loop.</p> <p>Be careful. Pressing this key when there is no disc mounted makes the spindle motor run at the maximum speed.</p> <p>If the focus servo does not go correctly into a closed loop or the laser light shines on the mirror section at the outermost periphery of the disc, the same symptom is occurred.</p>
□□	PAUSE	Tracking servo close/open	<p>Pressing this key when the focus servo and spindle servo are operating correctly in closed loops puts the tracking servo into a closed loop, displays the track number being played back and the elapsed time on the front panel, and outputs the playback signal.</p> <p>If the elapsed time is not displayed or not counted correctly or the audio is not played back correctly, it may be that the laser is shining on the section with no sound recorded at the outer edge of the disc, that something is out of adjustment, or that there is some other problem.</p> <p>This key is a toggle key and open/close the tracking servo alternately. This key has no effect if no disc is mounted.</p>

Code	Key name	Function In test mode	Explanation
◀◀	MANUAL SEARCH REV	Carriage reverse (inwards)	Moves the pickup position toward the inner diameter of the disc. When this key is pressed with the tracking servo in a closed loop, the tracking servo automatically goes into an open loop. Since the motor does not automatically stop at the mechanical end point in test mode, be careful with this operation.
▶▶	MANUAL SEARCH FWD	Carriage forward (outwards)	Moves the pickup position toward the outer diameter of the disc. When this key is pressed with the tracking servo in a closed loop, the tracking servo automatically goes into an open loop. Since the motor does not automatically stop at the mechanical end point in test mode, be careful with this operation.
□	STOP	Stop	Switches off all the servos and initialized. The pickup remains where it was when this key was pressed.
△	OPEN/CLOSE	Disc tray open/close	Open/close the disc tray. This key is a toggle key and open/close tray alternately. Pressing this key when the disc is turning stops the disc, then opens the tray. This key operation does not affect the position of the pickup.

[How to play back a disc in test mode]

In test mode, since the servos operate independently, playing back a disc requires that you operate the keys in the correct order to close the servos.

Here is the key operation sequence for playing back a disc in test mode.

PROGRAM	Lights up the laser diode and closes the focus servo.
↓	
PLAY ▶	Starts the spindle motor and closes the spindle servo.
↓	
PAUSE ⏸	Closes the tracking servo.

Wait at least 2-3 seconds between each of these operations.

1. Focus Offset Adjustment

● Objective	Sets the DC offset for the focus error amp.		
● Symptom when out of adjustment	The model does not focus in and the RF signal is dirty.		
● Measurement instrument connections	Connect the oscilloscope to TP1, Pin 6 (FCS. ERR)	● Player state	Test mode, stopped (just the Power switch on)
	[Settings] 5 mV/division 10 ms/division DC mode	● Adjustment location	VR103 (FCS. OFS)
		● Disc	None needed

[Procedure]

Adjust VR103 (FCS. OFS) so that the DC voltage at TP1, Pin 6 (FCS. ERR) is -150 ± 50 mV.

2. Grating Adjustment

<ul style="list-style-type: none"> ● Objective 	To align the tracking error generation laser beam spots to the optimum angle on the track.		
<ul style="list-style-type: none"> ● Symptom when out of adjustment 	Play does not start, track search is impossible, tracks are skipped.		
<ul style="list-style-type: none"> ● Measurement instrument connections 	Connect the oscilloscope to TP1, Pin 2 (TRK. ERR) via a low pass filter. (See Figure 2) [Settings] 50 mV/division 5 ms/division DC mode	<ul style="list-style-type: none"> ● Player state ● Adjustment location ● Disc 	Test mode, focus and spindle servos closed and tracking servo open Pickup grating adjustment slit 12-cm disc. (YEDS-7 can not be used.)

[Procedure]

1. Move the pickup to the outer edge of the disc with the MANUAL SEARCH FWD $\triangleright\triangleright$ or REV $\triangleleft\triangleleft$ key.
2. Press the PROGRAM key, then the PLAY \triangleright key in that order to close the focus servo then the spindle servo.
3. Insert an ordinary screwdriver into the grating adjustment slit and adjust the grating to find the null point. For more details, see the next page.
4. If you slowly turn the screwdriver counterclockwise from the null point, the amplitude of the wave gradually increases, then if you continue turning the screwdriver, the amplitude of the wave becomes smaller again. Turn the screwdriver counterclockwise from the null point and set the grating to the first point where the wave amplitude reaches its maximum.

Reference : Figure 3 shows the relation between the angle of the tracking beam with the track and the waveform.

Note : The amplitude of the tracking error signal is about 3 Vp-p (when a $39\text{ k}\Omega + 0.001\ \mu\text{F}$ low pass filter is used). If this amplitude is extremely small (2 Vp-p or less), the objective lens or the pickup malfunction may be the cause. If the difference between the amplitude of the error signal at the innermost edge and outermost edge of the disc is more than 10%, the grating is not adjusted to the optimum point, so adjust it again.

5. Return the pickup to more or less midway across the disc with the MANUAL SEARCH REV $\triangleleft\triangleleft$ key, press the PAUSE \square key and double check that the track number and elapsed time are displayed on the front panel. If they are not displayed at this time or the elapsed time changes irregularly, double check the null point and adjust the grating again.

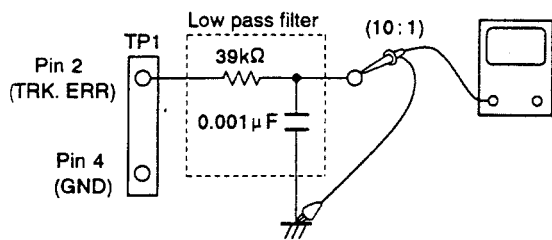
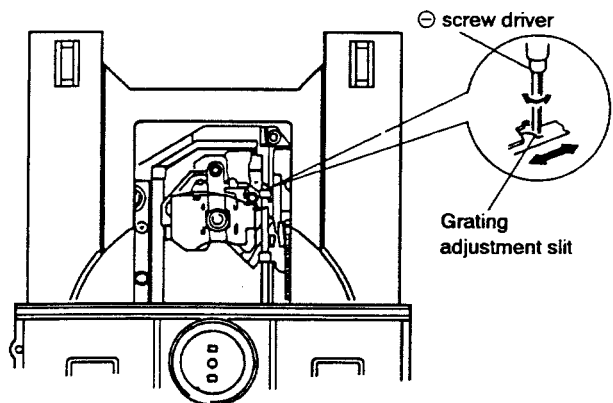

Figure 2



Adjustment locations

[How to find the null point]

When you insert the regular screwdriver into the slit for the grating adjustment and change the grating angle, the amplitude of the tracking error signal at TP1, Pin 2 changes. Within the range for the grating, there are five or six locations where the amplitude of the wave reaches a minimum. Of these five or six locations, there is only one at which the envelope of the waveform is smooth. This location is where the three laser beams divided by the grating are all right above the same track. (See Figure 3.)

This point is called the null point. When adjusting the grating, this null point is found and used as the reference position.

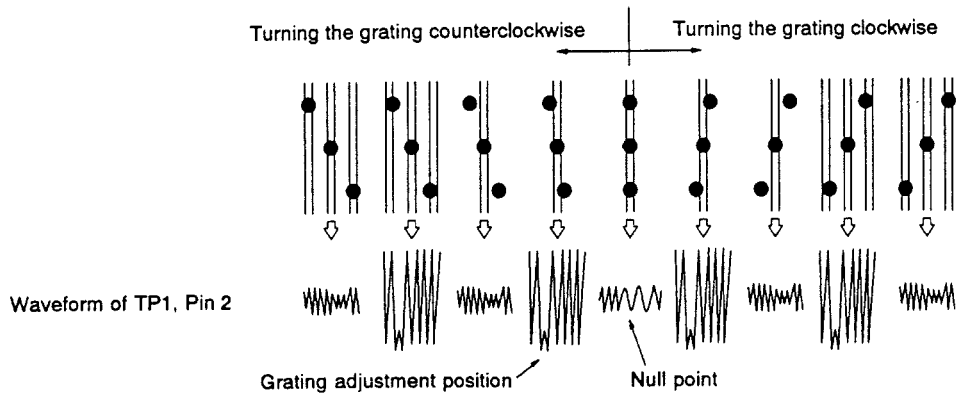
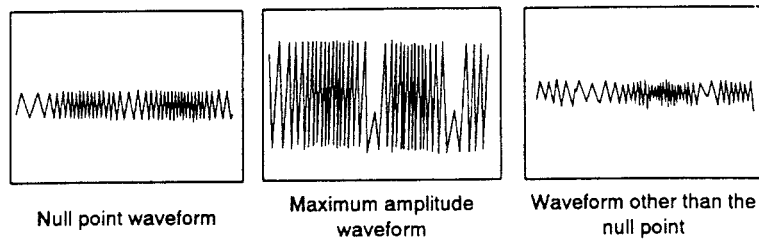

Figure 3



3. Tracking Error Balance Adjustment

● Objective	To correct for the variation in the sensitivity of the tracking photodiode.		
● Symptom when out of adjustment	Play does not start or track search is impossible.		
● Measurement instrument connections	Connect the oscilloscope to TP1, Pin 2 (TRK. ERR). This connection may be via a low pass filter. [Settings] 50 mV/division 5 ms/division DC mode	● Player state ● Adjustment location ● Disc	Test mode, focus and spindle servos closed and tracking servo open VR102 (TRK. BAL) YEDS-7

[Procedure]

1. Move the pickup to midway across the disc (R=35 mm) with the MANUAL SEARCH FWD $\triangleright\triangleright$ or REV $\triangleleft\triangleleft$ key.
2. Press the PROGRAM key, then the PLAY \triangleright key in that order to close the focus servo then the spindle servo.
3. Line up the bright line (ground) at the center of the oscilloscope screen and put the oscilloscope into DC mode.
4. Adjust VR102 (TRK. BAL) so that the positive amplitude and negative amplitude of the tracking error signal at TP1, Pin 2 (TRK. ERR) are the same (in other words, so that there is no DC component).

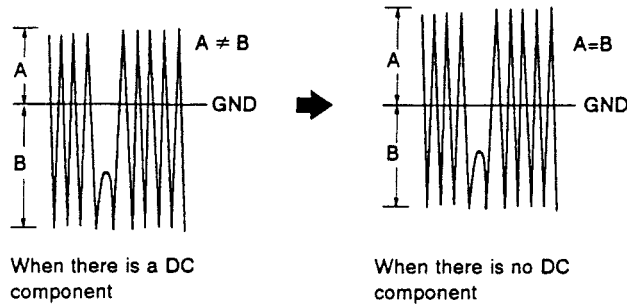

4. Pickup Radial/Tangential Tilt Adjustment

<ul style="list-style-type: none"> ● Objective 	To adjust the angle of the pickup relative to the disc so that the laser beams are shone straight down into the disc for the best read out of the RF signals.		
<ul style="list-style-type: none"> ● Symptom when out of adjustment 	Sound broken; some discs can be played but not others.		
<ul style="list-style-type: none"> ● Measurement instrument connections 	Connect the oscilloscope to TPI, Pin 1 (RF). [Settings] 20 mV/division 200 ns/division AC mode	<ul style="list-style-type: none"> ● Player state ● Adjustment location ● Disc 	Test mode, play Pickup radial tilt adjustment screw and tangential tilt adjustment screw 12- cm disc. (YEDS-7 can not be used.)

[Procedure]

1. Press the MANUAL SEARCH FWD >> or REV << key so that the radial / tangential tilt screws can be adjusted. Press the PROGRAM key, the PLAY > key, then the PAUSE || key in that order to close the focus servo then the spindle servo and put the player into play mode.
2. First, adjust the radial tilt adjustment screw with an 1.5mm hexagonal wrench so that the eye pattern (the diamond shape at the center of the RF signal) can be seen the most clearly.
3. Next, adjust the tangential tilt adjustment screw with an 1.5mm hexagonal wrench so that the eye pattern (the diamond shape at the center of the RF signal) can be seen the most clearly (Figure 5).
4. Adjust the radial tilt adjustment screw and the tangential tilt adjustment screw again so that the eye pattern can be seen the most clearly. As necessary, adjust the two screws alternately so that the eye pattern can be seen the most clearly.

Note:Radial and tangential mean the directions relative to the disc shown in Figure 4.

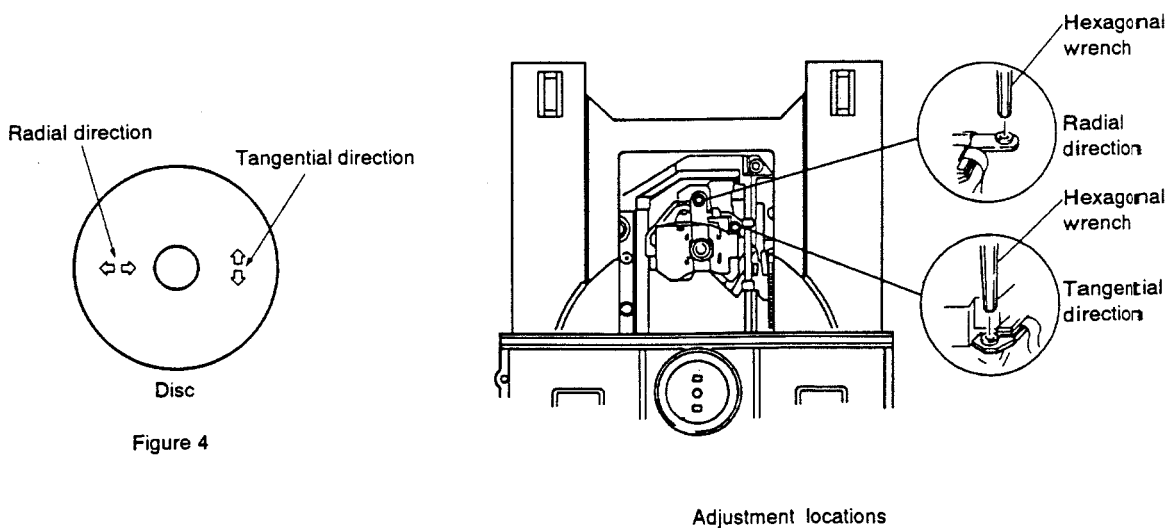

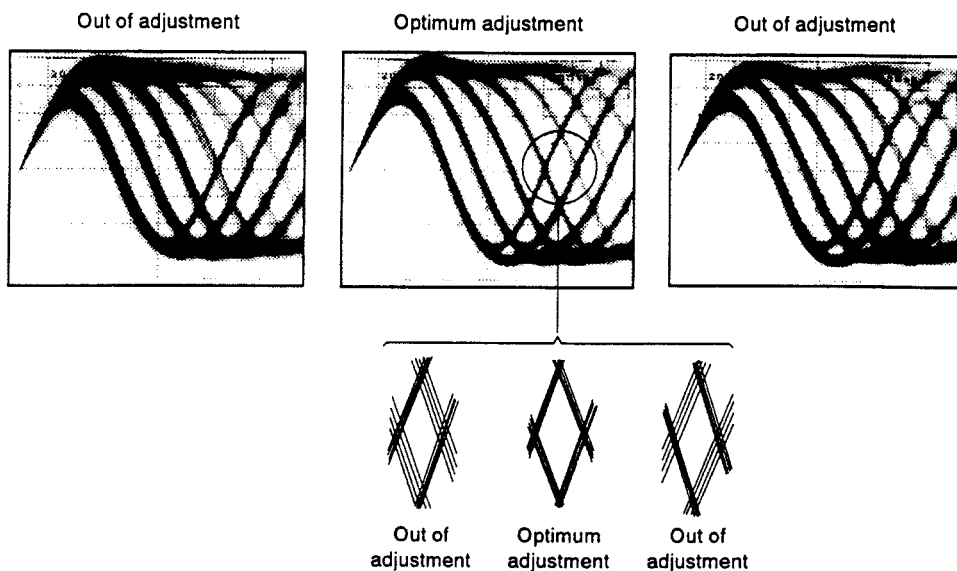

Figure 5 Eye pattern

5. RF Level Adjustment

● Objective	To optimize the playback RF signal amplitude		
● Symptom when out of adjustment	No play or no search		
● Measurement instrument connections	Connect the oscilloscope to TPI, Pin 1 (RF).	● Player state	Test mode, play
	[Settings] 50 mV/division 10 ms/division AC mode	● Adjustment location	VR1(laser power)
		● Disc	YEDS-7

[Procedure]

1. Move the pickup to midway across the disc (R=35 mm) with the MANUAL SEARCH FWD ▷▷ or REV ◁◁ key, then press the PROGRAM key, then the PLAY ▷ key in that order to close the respective servos and put the player into play mode.
2. Adjust VR1 (laser power) so that the RF signal amplitude is $1.2 \text{ V}_{p-p} \pm 0.1 \text{ V}$.

6. Focus Servo Loop Gain Adjustment

● Objective	To optimize the focus servo loop gain.		
● Symptom when out of adjustment	Playback does not start or focus actuator noisy.		
● Measurement instrument connections	See figure 6.	● Player state	Test mode, play
	[Settings] CH1 CH2 20 mV/division 5 mV/division X-Y mode	● Adjustment location	VR152 (FCS. GAN)
		● Disc	YEDS-7

[Procedure]

1. Set the AF generator output to 1.2 kHz and 1 Vp-p.
2. Press the MANUAL SEARCH FWD >> or REV << key to move the pickup to halfway across the disc (R=35 mm), then press the PROGRAM key, the PLAY > key, then the PAUSE || key in that order to close the corresponding servos and put the player into play mode.
3. Adjust VR152 (FCS. GAN) so that the Lissajous waveform is symmetrical about the X axis and the Y axis.

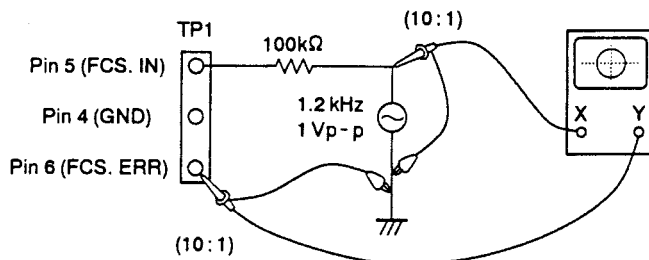
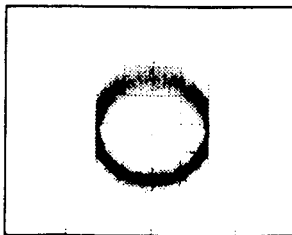

Figure 6

Focus Gain Adjustment



Higher gain



Optimum gain

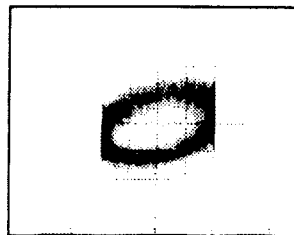

Lower gain

7. Tracking Servo Loop Gain Adjustment

● Objective	To optimize the tracking servo loop gain.		
● Symptom when out of adjustment	Playback does not start, during searches the actuator is noisy, or tracks are skipped.		
● Measurement instrument connections	See Figure 7.	● Player state	Test mode, play
	[Settings] CHI CH2 50 mV/division 20 mV/division X-Y mode	● Adjustment location	VR151 (TRK. GAN)
		● Disc	YEDS-7

[Procedure]

1. Set the AF generator output to 1.2 kHz and 2 Vp-p.
2. Press the MANUAL SEARCH FWD >> or REV << key to move the pickup to halfway across the disc (R=35 mm), then press the PROGRAM key, the PLAY > key, then the PAUSE || key in that order to close the corresponding servos and put the player into play mode.
3. Adjust VR151 (TRK. GAN) so that the Lissajous waveform is symmetrical about the X axis and the Y axis.

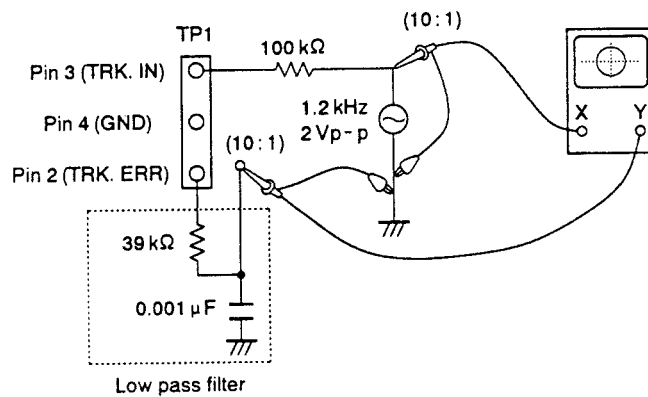
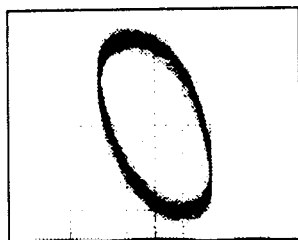
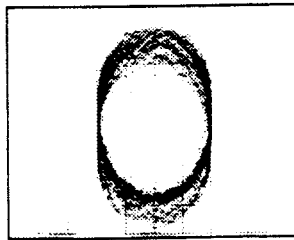

Figure 7

Tracking Gain Adjustment



Higher gain



Optimum gain

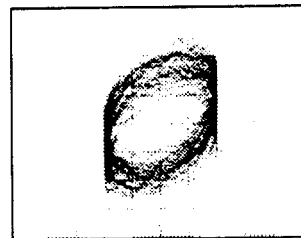

Lower gain

8. Focus Error Signal (Focus S Curve) Verification

<ul style="list-style-type: none"> ● Objective ● Symptom when out of adjustment 	To judge whether the pickup is ok or not by observing the focus error signal. The pickup is judged from the amplitude of the tracking error signal (as discussed in the section on adjusting the tracking error balance) and the waveform for the focus error signal.		
<ul style="list-style-type: none"> ● Measurement instrument connections 	Connect the oscilloscope to TPI, Pin 6 (FCS. ERR). [Settings] 100 mV/division 5 ms/division DC mode	<ul style="list-style-type: none"> ● Player state ● Adjustment location ● Disc 	Test mode, stop None YEDS-7

[Procedure]

1. Connect TPI Pin 5 to ground.
2. Mount the disc.
3. While watching the oscilloscope screen, press the PROGRAM key and observe the waveform in Figure 8 for a moment. Verify that the amplitude is at least 2.5 Vp-p and that the positive and negative amplitude are about equal. Since the waveform is only output for a moment when the PROGRAM key is pressed, press this key over and over until you have checked the waveform.

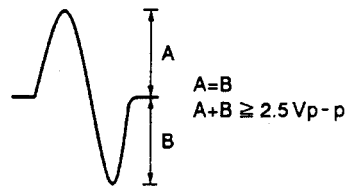

Figure 8

[Judging the pickup]

Do not judge the pickup until all the adjustments have been made correctly. In the following cases, there may be something wrong with the pickup.

1. The tracking error signal amplitude is extremely small (less than 2 Vp-p).
2. The focus error signal amplitude is extremely small (less than 2.5 Vp-p).
3. The positive and negative amplitudes of the focus error signal are extremely asymmetrical (2 : 1 ratio or more).
4. The RF signal is too small (less than 0.8 Vp-p) and even if VRI (laser power) is adjusted , the RF signal can not be brought up to the standard level.

7. FOR PD-201/KC, KUXJS, KCXJS, PD-101/KU, KC, KUXJS AND KCXJS TYPES

NOTES:

- Parts without part number cannot be supplied.
- The Δ mark found on some component parts indicates the importance of the safety factor of the part. Therefore, when replacing, be sure to use parts of identical designation.
- Parts marked by "⊙" are not always kept in stock. Their delivery time may be longer than usual or they may be unavailable.

PD-201/KC, KUXJS, KCXJS, PD-101/KU, KC, KUXJS, KCXJS and PD-201/KU have the same construction except for the following:

Mark	Symbol & Description	Part No.							
		PD-201/ KU type	PD-201/ KC type	PD-201/ KUXJS type	PD-201/ KCXJS type	PD-101/ KU type	PD-101/ KC type	PD-101/ KUXJS type	PD-101/ KCXJS type
	Display window B	PAM1543	PAM1543	PAM1543	PAM1543
	Display window A	PAM1542	PAM1542	PAM1542	PAM1542
	32P F.F.C/30V	PDD1041	PDD1041	PDD1041	PDD1041
	30P F.F.C/30V	PDD1049	PDD1049	PDD1049	PDD1049
	Function panel assembly	PEA1191	PEA1191	PEA1191	PEA1191	PEA1192	PEA1192	PEA1192	PEA1192
	CD Packing case	PHG1748	PHG1822	PHG1762	PHG1825	PHG1747	PHG1821	PHG1760	PHG1824
	Function panel C	PNW2195	PNW2195	PNW2195	PNW2195
	Function panel A	PNW2194	PNW2194	PNW2194	PNW2194
	Bonnet	PYY1147	PYY1147	PYY1129	PYY1129	PYY1147	PYY1147	PYY1129	PYY1129
	Operating Instructions (English)	PRB1159	PRB1159	PRB1159	PRB1159
	Operating Instructions (English /German)	PRE1154	PRE1154	PRE1154	PRE1154
⊙	Mother board assembly	PWM1657	PWM1657	PWM1657	PWM1657	PWM1653	PWM1653	PWM1653	PWM1653
⊙	Sub board assembly	PWX1214	PWX1214	PWX1214	PWX1214	PWX1213	PWX1213	PWX1213	PWX1213
	└ Function board assembly	Non supply	Non supply	Non supply	Non supply	Non supply	Non supply	Non supply	Non supply
	Remote control unit (CU-PD046)	PWW1081	PWW1081	PWW1081	PWW1081

MOTHER BOARD ASSEMBLY (PWM1653)

PWM1653 and PWM1657 have the same construction except for the following:

Mark	Symbol & Description	Part No.		Remarks
		PWM1657	PWM1653	
	C417	CKCYF103Z50	
	C433.C434	PCH1107	CEAS220M25	
	C451, C452	CEAS4R7M50	
	D391	1SS254	
	IC405	NJM4565D-D	NJM4558D-D	
	L301	LAU010K	
	Q451, Q452	DTA124ES	
	Q453, Q454	2SB1296	
	R406, R407	RD1/6PM471J	
	R445, R446	RD1/6PM271J	RD1/6PM471J	
	R451, R452	RD1/6PM473J	
	R453, R454	RD1/6PM470J	
	R455-R458	RD1/6PM102J	
	R459-R462	RD1/6PM271J	
	CN351	HLEM32S-1	HLEM30S-1	

FUNCTION BOARD ASSEMBLY

Function board assemblies of PD-101/KU, KC, KUXJS, KCXJS and PD-201/KU have the same construction except for the following:

Mark	Symbol & Description	Part No.		Remarks
		PD-201/KU type	PD-101/KU, KC, KUXJS and KCXJS types	
	CN701 FFC connector (32P)	HLEM32R-1	
	CN701 FFC connector (30P)	HLEM30R-1	
	Remote control detector	SBX1610-51	

8. PANEL FACILITIES

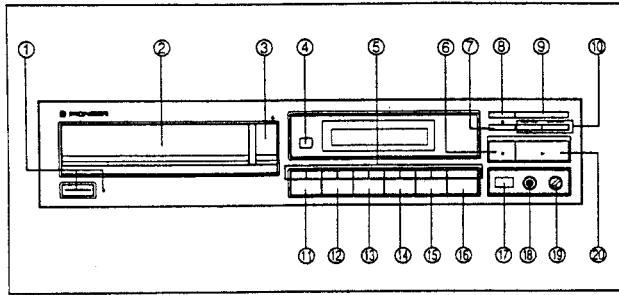

FRONT PANEL

- ① **POWER STANDBY/ON switch and STANDBY indicator**
- ② **Disc tray**
- ③ **OPEN/CLOSE button (▲)**
- ④ **Remote sensor**
Receives the signal from the remote control unit.
• The PD-101 is not equipped with the remote sensor.
- ⑤ **TRACK NUMBER/Digit buttons (1 - 10, >10)**
- ⑥ **Pause button (II)**
- ⑦ **Stop button (■)**
- ⑧ **REPEAT button**
- ⑨ **RANDOM PLAY button**
- ⑩ **Track/Manual search buttons (◀◀ ◀▶▶ ▶▶)**
- ⑪ **PROGRAM button**
- ⑫ **CHECK button**
- ⑬ **CLEAR button**
- ⑭ **HI-LITE SCAN button**
- ⑮ **COMPU/AUTO EDIT button**
- ⑯ **TIME button**
- ⑰ **PEAK SEARCH button**
- ⑱ **Headphones jack (PHONES)**
- ⑲ **Headphones volume control (LEVEL)**
- ⑳ **Play button (▶)**

9. SPECIFICATIONS

1. General

Type	Compact disc digital audio system
Power requirements	
European model	AC 220 - 240 V, 50/60 Hz
U.K. and Australian models	AC 220 - 240 V, 60 Hz
U.S. and Canadian models	AC 120 V, 60Hz
Other models	AC 110 - 127/220 - 240 V (Switchable), 50/60 Hz
Power consumption	
U.S. and Canadian models	12 W
Other models	13 w
Operating temperature	+5°C - +35°C +41°F - +95°F
Weight	3.5 kg (7 lb, 12 oz)
External dimensions	
U.S., Canadian, U.K. and European models	420(W) X 276(D) X 101(H) mm 16-9/16(W) X 10-7/8(D) X 4(H) in
Other models	420(W) X 276(D) X 96(H) mm 16-9/16(W) X 10-7/8(D) X 3-3/4(H) in

2. Audio section

Frequency response	2 Hz - 20 kHz
S/N ratio	
U.S. and Canadian models of PD-101	98 dB or more (EIAJ)
Other models	102 dB or more (EIAJ)
Dynamic range	96 dB or more (EIAJ)
Harmonic distortion	0.003% or less (EIAJ)
Output voltage	2.0V
Wow and flutter	Limit of measurement (±0.001% W.PEAK) or less (EIAJ)
Channels	2-channel (stereo)

3. Output terminal

Audio line output jacks
Control input/output jacks (available with the PD-101 and U.S. and Canadian models of the PD-201 only; Not available with models for military zones (multi-voltage types))
CD-DECK SYNCHRO jack
Headphone jack (with volume control)

4. Accessories

• Remote control unit (PD-201 only)	1
• Size AAA/R03/dry batteries (PD-201 only)	2
• Control cord (provided with PD-101 and U.S. and Canadian models of PD-201 only; Not available with models for military zones (multi-voltage types))	1
• Output cable	1
• Operating instructions	1

NOTE:

Specifications and design subject to possible modification without notice, due to improvements.